

# Parklets



PAY  
METER  
HERE  
↓

11

TOW ZONE  
NO  
STANDING  
PERMITTED  
MOVING  
VEHICLES ONLY

# PARKLETS

## Overview

Boston has many vibrant Main Street Districts, which are home to the local businesses that give each neighborhood its unique character. These spaces serve as community gathering places, but in many of them there is actually very little public space for gathering. In Main Street Districts and other areas of Boston with narrow sidewalks and limited access to parks, Parklets can offer new outdoor gathering spaces and bring new activity to the street and nearby businesses.

A Parklet repurposes part of the street, typically one or two parking spaces, into a public space in which people can gather and socialize. In cities across the country, Parklets play an important role in neighborhood placemaking, encouraging community interactions and a vibrant street life.

Parklets introduce new streetscape features such as seating, plantings, art, and bicycle parking on a platform extending into the parking lane of the street. Parklets are typically sponsored by a nearby business or community organization, but Parklets are public and open to everyone, not just customers of a specific business. For table service or private parklets, refer to Outdoor Cafe guidelines (see pg. 21).

A City-sponsored parklet may not become private. If the partner wishes to replace a public parklet with a private one, they will need to independently apply through the Outdoor Cafe permitting process with the Public Improvement Commission.

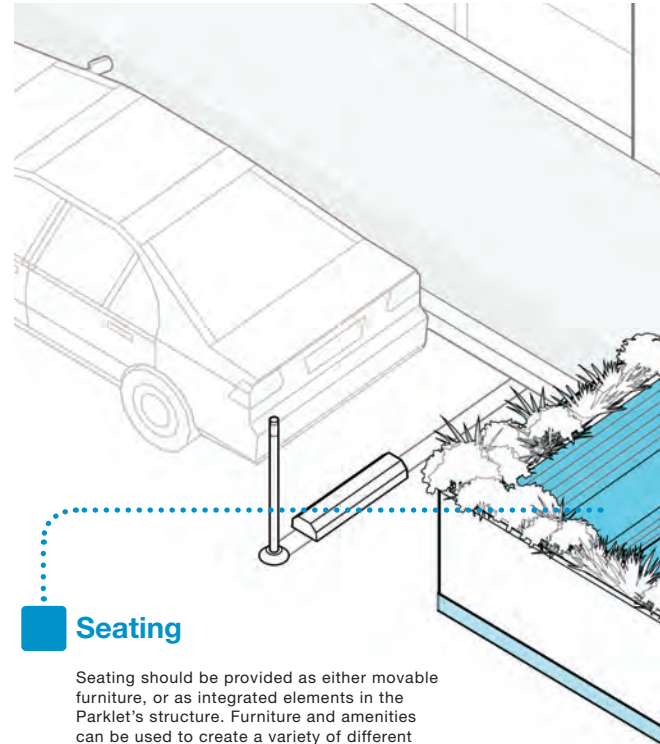
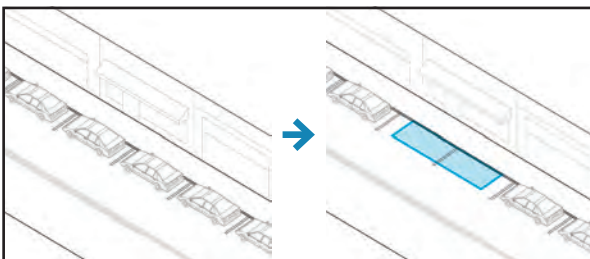

### Seating

Seating should be provided as either movable furniture, or as integrated elements in the Parklet's structure. Furniture and amenities can be used to create a variety of different social spaces. Five percent of seating must be accessible for persons with disabilities.

### Barrier

A barrier separates the Parklet from the roadway, protecting users from motorists while also defining the space. Barriers with some level of transparency are preferred to provide visual interest.

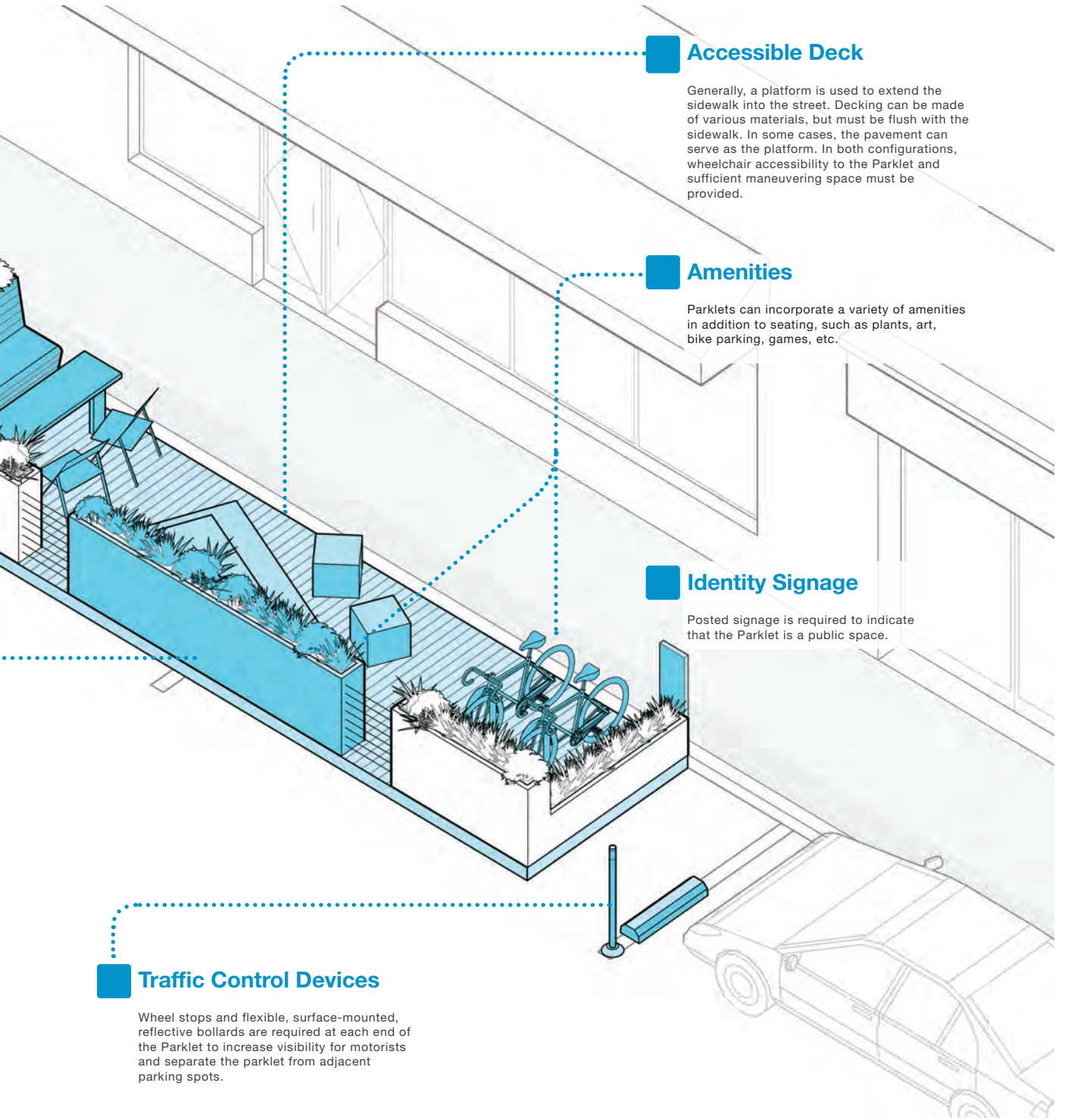
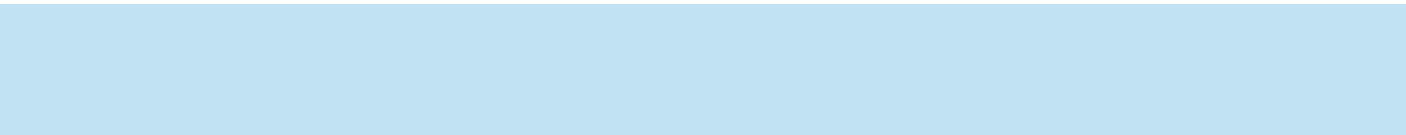

### Accessible Deck

Generally, a platform is used to extend the sidewalk into the street. Decking can be made of various materials, but must be flush with the sidewalk. In some cases, the pavement can serve as the platform. In both configurations, wheelchair accessibility to the Parklet and sufficient maneuvering space must be provided.

### Amenities

Parklets can incorporate a variety of amenities in addition to seating, such as plants, art, bike parking, games, etc.

### Identity Signage

Posted signage is required to indicate that the Parklet is a public space.

### Traffic Control Devices

Wheel stops and flexible, surface-mounted, reflective bollards are required at each end of the Parklet to increase visibility for motorists and separate the parklet from adjacent parking spots.

# Context and Location Criteria

Parklets are best suited for streets that have relatively narrow sidewalks and no public open space in the immediate vicinity. They are especially well-suited to neighborhood business districts like small Main Street Districts, where there is a concentration of street activity, but retail footprints are smaller, and sidewalks often lack space for benches or outdoor seating. Parklets should be located as close as possible to existing hubs of activity, such as cafes, shops, and other popular destinations. The most successful Parklets are in the center of a business district, and are immediately adjacent to an active ground-floor use.

There are a few types of locations where siting a successful Parklet may be more difficult. Parklets are less well suited for busy arterial streets with heavy or fast-moving traffic. Also, Parklets may serve no real purpose if they are located too close to an existing public open space, such as a park.



## General Requirements

<b>Speed Limit</b>	Parklets are permitted on streets regulated at or below the default speed limit of 25 mph.
<b>Street Slope</b>	Parklets are allowed on streets with a running slope of 5% or less.
<b>Public Utilities</b>	Parklets must not block fire hydrants or cover any utility or manhole covers.
<b>Water Drainage</b>	Parklets must not be installed over street drains unless accommodations for water flow are made.
<b>Existing Public Right of Way</b>	Parklets must not obstruct other street furniture, plantings, or signage. Electrical cords may not run across the public right of way from a partner establishment to a Parklet.
<b>Paving Schedule</b>	Parklets should not be installed in locations scheduled for resurfacing or utility work within 8 months of installation.
<b>Assembly and Disassembly</b>	Parklets must be easy to assemble on site and dismantle for storage or in case of emergency hazard situations. Components must be transportable by a standard pickup truck when disassembled.



Top: Parklet in Roslindale, Boston  
 Bottom: Parklet in San Francisco

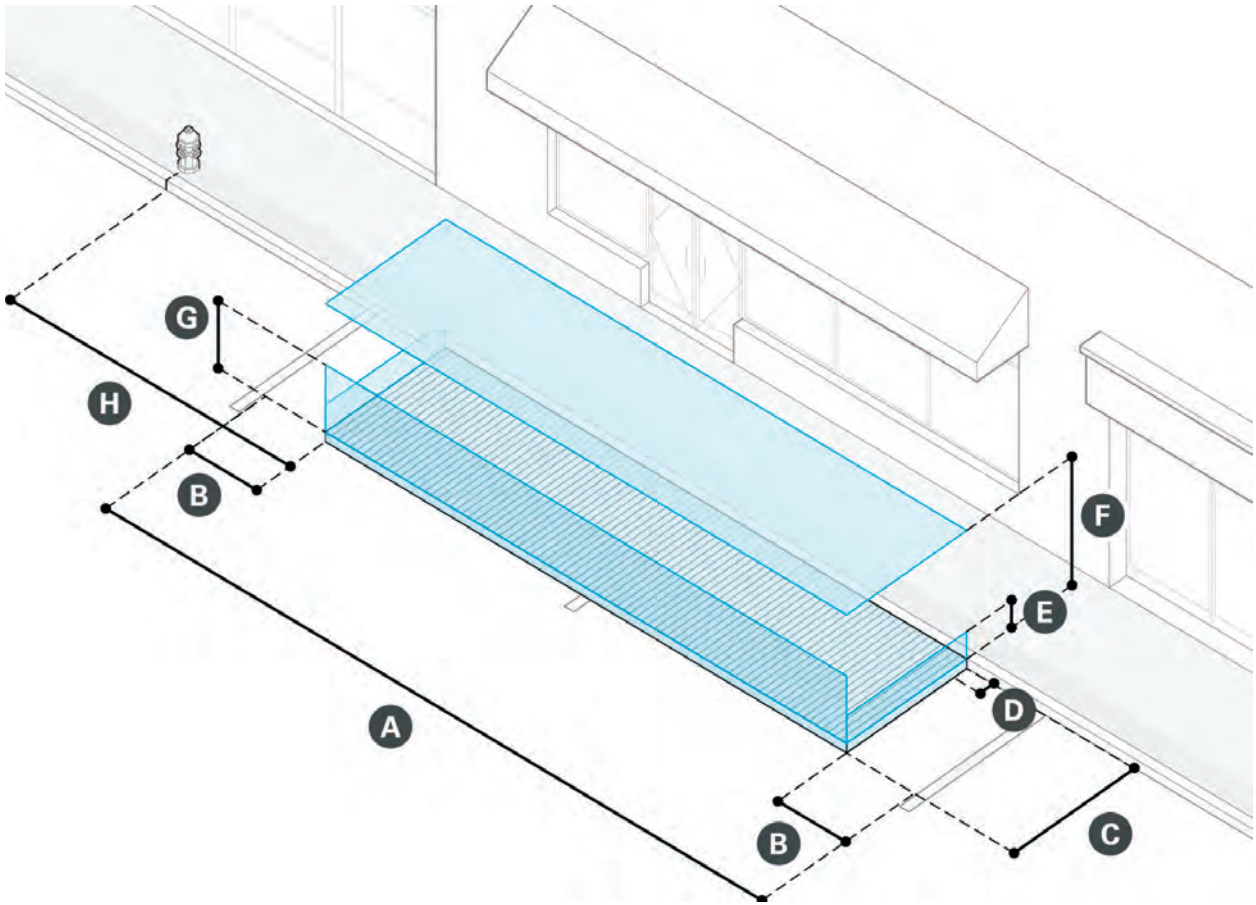

An accessible curb ramp and platform can also be used to create a Parklet directly on the pavement:

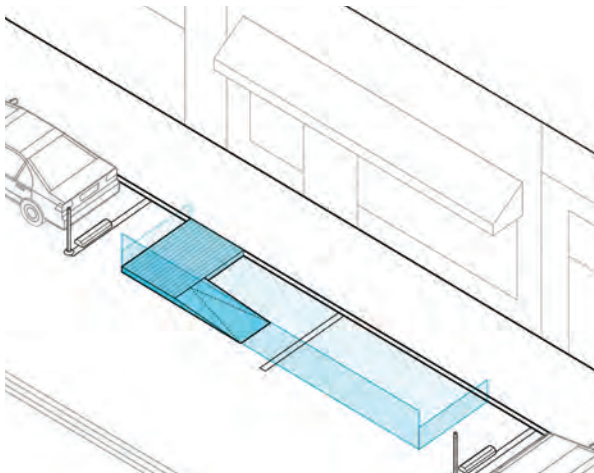

### Design and Placement

<b>A</b>	Typical width occupied along street	2 parking spaces
<b>B</b>	Distance from platform to wheel stop	3'
<b>C</b>	Maximum parklet width from curb	7'
<b>D</b>	Platform is flush with curb and maintains curblines drainage	
<b>E</b>	Minimum side edge height	17"
<b>F</b>	Minimum overhead clearance	80"
<b>G</b>	Street edge height	36–42"
<b>H</b>	Minimum distance from fire hydrant to Parklet	15'

# Application and Implementation Process

Each year the City may fund one to two Parklets. Additional Parklets may be implemented if fully funded by community partners. The process for privately-funded Parklets is the same, except that the partner must provide their own design consultant and contractor.

The application process outlined below is only for Boston Transportation Department (BTD) sponsored Parklets and may not be used for privately managed cafe seating applications. Guidelines for Outdoor Cafes can be found on page 21.

## 1 Nominate a location for a Parklet and submit application to BTD

Application guidelines can be found at [www.boston.gov/publicrealm](http://www.boston.gov/publicrealm).

Applications must include:

- ▶ street-level photos of the site to describe its existing conditions, and an aerial image diagram to indicate the proposed Parklet location.
- ▶ letters of support from abutters and local organizations, such as resident associations and business groups

## 2 Initial review by the City

Applications will be evaluated and selected based on criteria which will be available at [www.boston.gov/publicrealm](http://www.boston.gov/publicrealm).

## 3 The City's on-call design consultant will work with the community partner to design the Parklet

- ▶ Applicant should expect to meet with BTD and the City's on-call consultant up to three times.
- ▶ Applicant is strongly encouraged to work with local artists and designers to contribute to the development of the Parklet design.

## 4 Proposal will be reviewed through a public process determined by the City and adjusted based on the feedback

## 5 The City's on-call design consultant presents to Public Improvement Commission (PIC) for administrative approval

## 6 Memorandum of Understanding (MOU)

Successful applicant becomes the official Parklet Partner by signing an MOU with the Public Improvement Commission (PIC). A sample is available at [www.boston.gov/publicrealm](http://www.boston.gov/publicrealm).

## 7 Design installed by City contractor

Parklets will be in place seasonally.

## Community Partner and City Roles

The long-term success of a Parklet will depend on community partners. Successful Parklets are embraced by those who use them, and are supported by community partners that provide “eyes on the Parklet” and have a true sense of ownership.

### Parklet Partner

#### Regular Maintenance

- ▶ Cleaning, trash removal, and plant watering are the responsibility of the Parklet Partner.

#### Day-to-Day Management

- ▶ Daily setup and breakdown of any items that cannot be left out overnight are the responsibility of the Parklet Partner.
- ▶ Selection of plaza furnishings should take into consideration the level of daily management required.

### City

- ▶ The City is responsible for dismantling the Parklet and storing it during the winter.
- ▶ The City is responsible for maintaining wheel stops and bollards.
- ▶ The City is responsible for reinstallation.

# Photo Credits

P iv: © MP Boston

P 3: © Irene Figueroa-Ortiz

P 4: © MP Boston

P 7: NYCDOT/Creative Commons

P 8: © Utile

P 12: © Jessica Robertson

P 16: (top) City of Boston/Public Domain

P 16: (bottom) © NACTO

P 20: MassDOT/Creative Commons

P 22: © Utile

P 30: © Galen Mook

P 32: (top) © Andrew Nahmias

P 32: (bottom) SDOT/Creative Commons

P 33: (top) © Galen Mook

P 33: (bottom left) © Paul Malkemes

P 33: (bottom right) © Galen Mook

P 34: (top) NYCDOT/Creative Commons

P 34: (bottom) NYCDOT/Creative Commons

P 37: © Galen Mook

P 38: © KZLA and Christian Phillips Photography