

Community Meeting # 4

Improvements to McKINNEY PLAYGROUND



June 4, 2024
Boston Parks and Recreation



Zoom Interpretation Services



English: For interpretation in [_ _ _ _],

1. Go to the horizontal control bar at the bottom of your screen. Click on “Interpretation.”
2. Then click on the language that you would like to hear.
3. You are now accessing this meeting in [_ _ _ _]

Mandarin: 若需普通话口译服务:

1. 在屏幕下方的长方形控制栏中，请点击“Intepretation.”
2. 请点击您所需收聽的语言。
3. 您即可收听普通话的会议口译。

Spanish: Para traducción en Español,

1. Vaya a la parte baja de la pantalla, en la barra horizontal, y presione la tecla “Interpretation”.
2. Luego seleccione el idioma que desea escuchar.
3. Después de seleccionar, usted entrará a la reunión en el idioma “Español”.

1.



2.

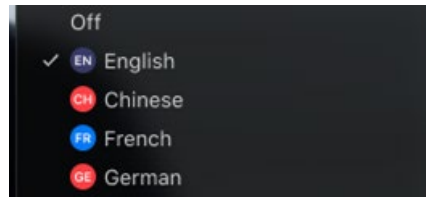

3.



Community Meeting # 4

Improvements to McKINNEY PLAYGROUND



June 4, 2024
Boston Parks and Recreation



MEETING RECORDING



The Boston Parks and Recreation Department will be recording the meeting and posting to our project webpage for those who are unable to attend the Zoom meeting live.

It is possible that participants may also be recording the meeting with their phones cameras or other devices. If you do not wish to be recorded during this meeting, please keep your microphone and camera off.

VIRTUAL MEETING ETIQUETTE

We want to ensure this conversation is a pleasant experience for all and that all community members/stakeholders are comfortable sharing their comments, questions and feedback.

Please be respectful and mindful of each other's time when asking questions/ providing comments, so that all attendees are able to participate in the meeting.

Keep questions/ comments project-specific and not personal to yield solution-driven discussion.

Please wait until all attendees have had the opportunity to ask a question/ provide a comment before providing additional questions/ comments.

You can always set up a conversation with NELLE WARD, nelle.ward@boston.gov, to further discuss the project or process.

ZOOM TIPS

Here is how you can participate during the question and answer part of the presentation.

DURING THE PRESENTATION:



VIA WEB:

Turn video on / off.

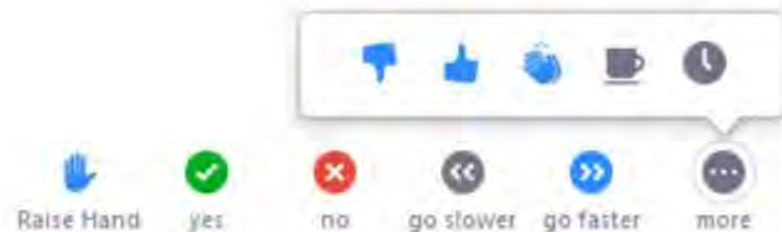

To use these non-verbal options click on participants (bottom of screen); these options will pop up in side bar.

DURING THE Q&A:



JOINING VIA PHONE?

Use *9 to raise hand to ask for audio / video permission to ask questions or provide comments.



VIA WEB:

Chat to ask questions / comments or provide responses to poll questions



Raise hand to ask for audio / video permission to ask questions or provide comments.

PROJECT OVERVIEW



AGENDA

1

PROJECT TEAM INTRODUCTION

2

PROJECT OVERVIEW

3

PRESENTATION

4

LISTENING & DISCUSSION

5

CLOSING REMARKS & NEXT STEPS

PROJECT TEAM

Nelle Ward

Project Manager

nelle.ward@boston.gov or 617-961-3035

Cathy Baker-Eclipse

Director of the Capital Plan

cathy.baker-eclipse@boston.gov or 617-961-3058

Kwanna Wise

Director of Community Engagement

kwanna.wise@boston.gov or 617-961-3006

Thammy Pierre-Louis

Community Outreach Coordinator

thamara.pierrelouis@boston.gov or 617-635-4863

Megan Tomkins

Principal, CBA Landscape Architects, LLC

Michelle Johnson

Landscape Designer, CBA Landscape Architects, LLC

Luke McCoy

Principal, Kaestle Boos Associates, Inc.

Sports Field Design Consultant





CITY OF BOSTON PRIORITIES

- **Family Friendly**
- **Green and Growing**
- **Healthy and Safe**
- **Delivering Exceptional City Services**
- **Closing the Racial Wealth Gap**



PARKS & RECREATION GOALS

- **Accessible and available to all**
- **Diverse, balanced and efficient mix of uses**
- **Meaningful and inclusive community engagement**
- **Adaptive and resilient landscapes**
- **Promote connections**



PROJECT RECAP



TIMELINE

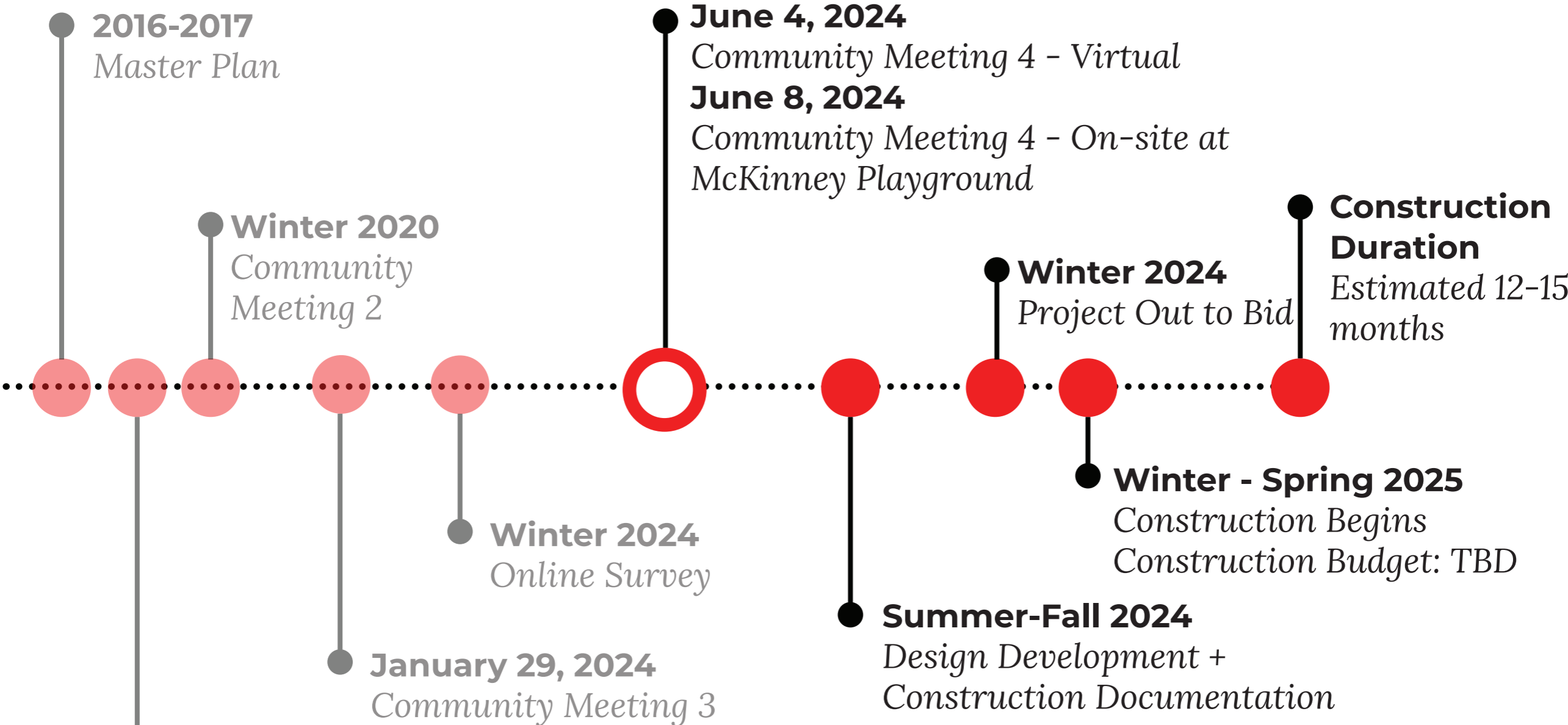

FUNDING SOURCES:
City of Boston
Boston College Neighborhood Improvement Fund

2017 MASTER PLAN



SUMMARY OF ELEMENTS

1. 8' wide asphalt perimeter path around sport fields.
2. Entry Plaza entry along Fanueil Street.
3. New enclosed play equipment area with splashpad, picnic tables, benches and game tables.
4. One basketball court with sports lights and one multi-sport court.
5. Community Garden area.
6. Relocated Little League, Baseball and Softball fields, including new benches, bleachers, extended height backstops/dugouts, and retaining walls/steps (Little League only).
7. Space for one soccer field (for ages 19 and under)
8. Exercise Equipment.
9. Electrical Scoreboard.
10. Benches along pathways.
11. Relocated storage unit and electrical utility box (additional storage unit near basketball/multi-sport courts.)

2020 MASTER PLAN

Artificial Turf Little League, Baseball, and Soccer Fields - No Softball Field



JANUARY 2024 CONCEPT PLAN | FIELD DESIGN OPTIONS



Artificial Turf



Natural Turf

Artificial Turf and **Natural Turf** were discussed as the two options for the sports field. The community preferred the **Natural Turf** option.

JANUARY 2024 CONCEPT PLAN | FIELD DESIGN OPTIONS



Artificial Turf



Natural Turf

Artificial Turf and **Natural Turf** were discussed as the two options for the sports field. The community preferred the **Natural Turf** option.

EXISTING CONDITIONS



NEIGHBORHOOD CONTEXT



LEGEND

- PARKS**
 1. McKinney Playground
 2. Birmingham Parkway
 3. Portsmouth Playground
 4. Ringer Playground
 5. Fidelis Way Park
 6. Brighton High Park
 7. Cunningham Park
 8. Rogers Park
 9. Hobart Park
- SCHOOL**
- HOSPITAL**

EXISTING CONDITIONS | PLAYGROUND, SPORT COURTS AND PARK

Basketball Courts



Street Hockey Court



Ages 5-12 Play Structure



Ages 2-5 Play Structure



View toward Leicester St.



View from Leicester St.



EXISTING CONDITIONS | SPORT FIELDS

Soccer



Softball



Little League



Baseball



EXISTING CONDITIONS | DRAINAGE DIAGRAM



USE ANALYSIS | PARK USAGE (2013-2019)

2017 MASTER PLAN: During the 2017 Master Plan, the park use permits from 2013-2016 were analyzed and there was **constant use of all 3 ball fields**.

2019-2020 COMMUNITY DESIGN PROCESS: CBA and the BPRD reviewed park use for 2017-2019 and all **3 ball fields were constantly being used** during **April-November**; however many of the use **permits pulled** for the Softball field were **for other sports**, like **Baseball, Little League or Soccer**.

USE ANALYSIS | PARK USAGE 2019-2023

2023-PRESENT: When BPRD restarted the McKinney Playground renovation design process in late 2023, we reexamined usage and permitting data for the park.

At this **time constant use** of all three fields was observed during **spring, summer, and fall**. However, **permitted use** of the field area was primarily by **youth sports leagues and programs**, with **heavy use by Little League and youth Softball**, and a **growing use by youth Soccer**. A **waning use by Baseball leagues** (youth, High School, and adult) was observed in this time period, and **potential growth** in use by **high school level Soccer** (MIAA regulation size field) was also understood.

USE ANALYSIS | PARK USAGE 2023

The chart below shows permitted park use for 2023 only.

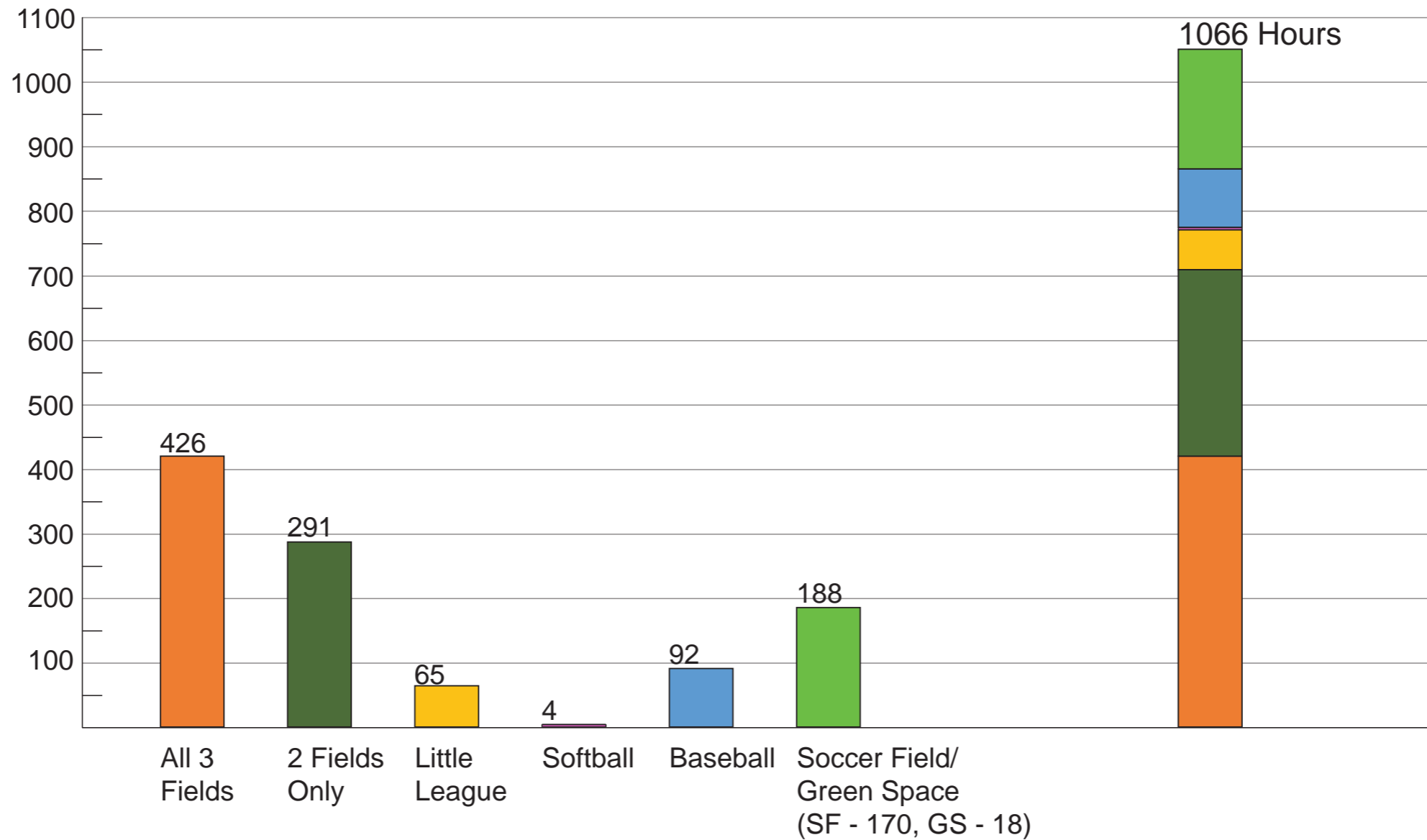

We understand that permitted uses are only a portion of how a public park is used. **Feedback provided at Community Meetings 1, 2, & 3 showed that neighbors use the fields at McKinney Playground for walking, relaxing, playing with/exercising dogs,** and many other uses.

COMMUNITY FEEDBACK

2024: COMMUNITY MEETING #3 & ONLINE SURVEY



COMMUNITY MEETING 3 | FEEDBACK ON FIELDS



Artificial Turf



Natural Turf

Artificial Turf and **Natural Turf** were discussed as the two options for the sports field. The community preferred the **Natural Turf** option.

ONLINE SURVEY | USER DEMOGRAPHICS

97 Total Responses!

92% of respondents were aged 31 and older

67% of respondents have kids ages 0-18

77% of responses were local residents

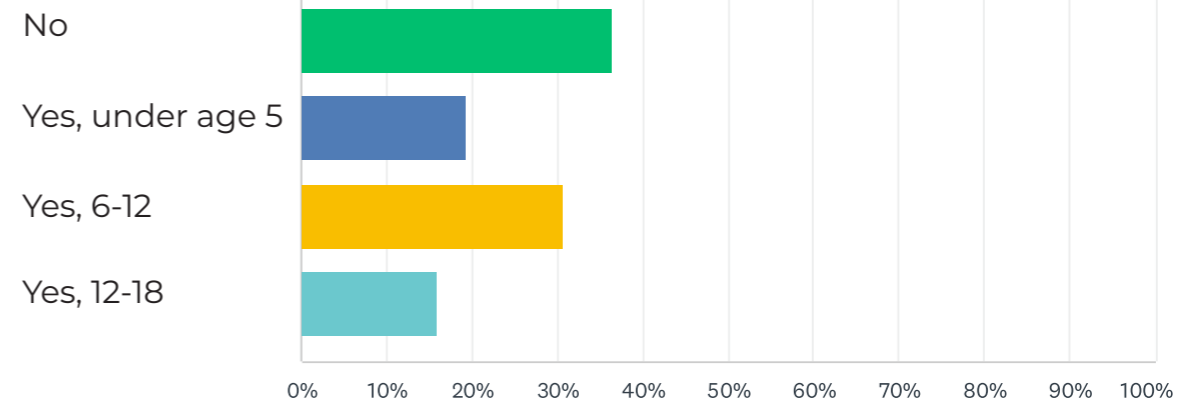
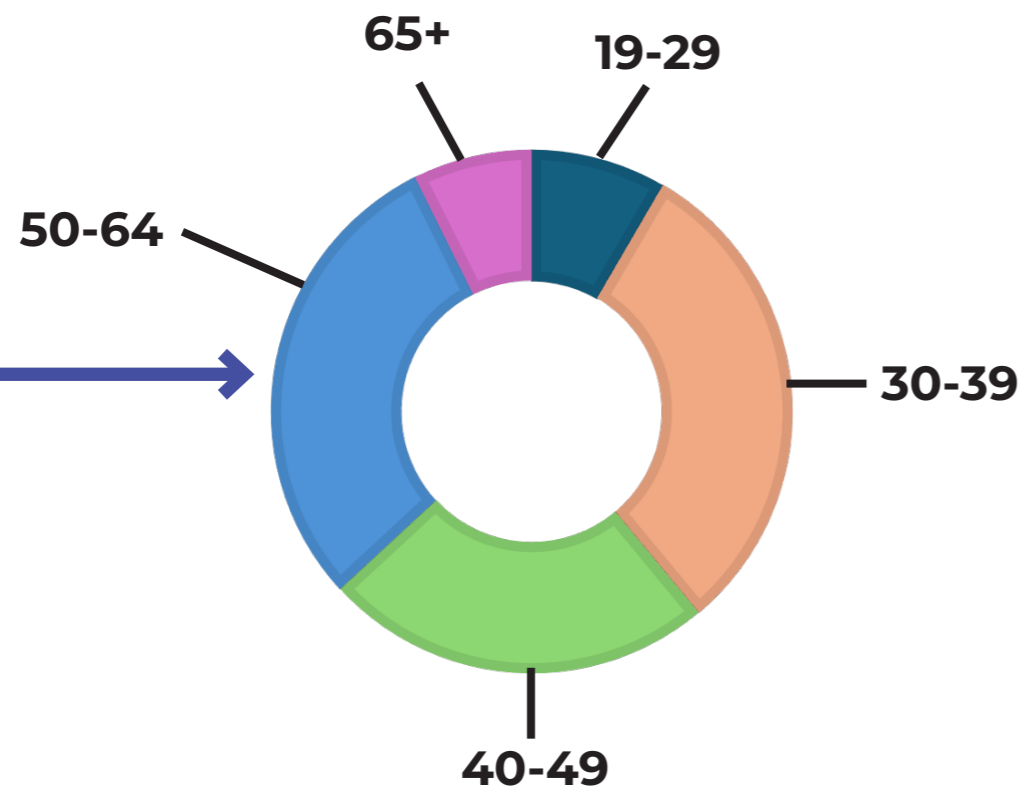

ONLINE SURVEY | PLAYGROUND

QUESTION: **What are your highest priority playground components for McKinney Playground.**

Answered: 97 Skipped: 0

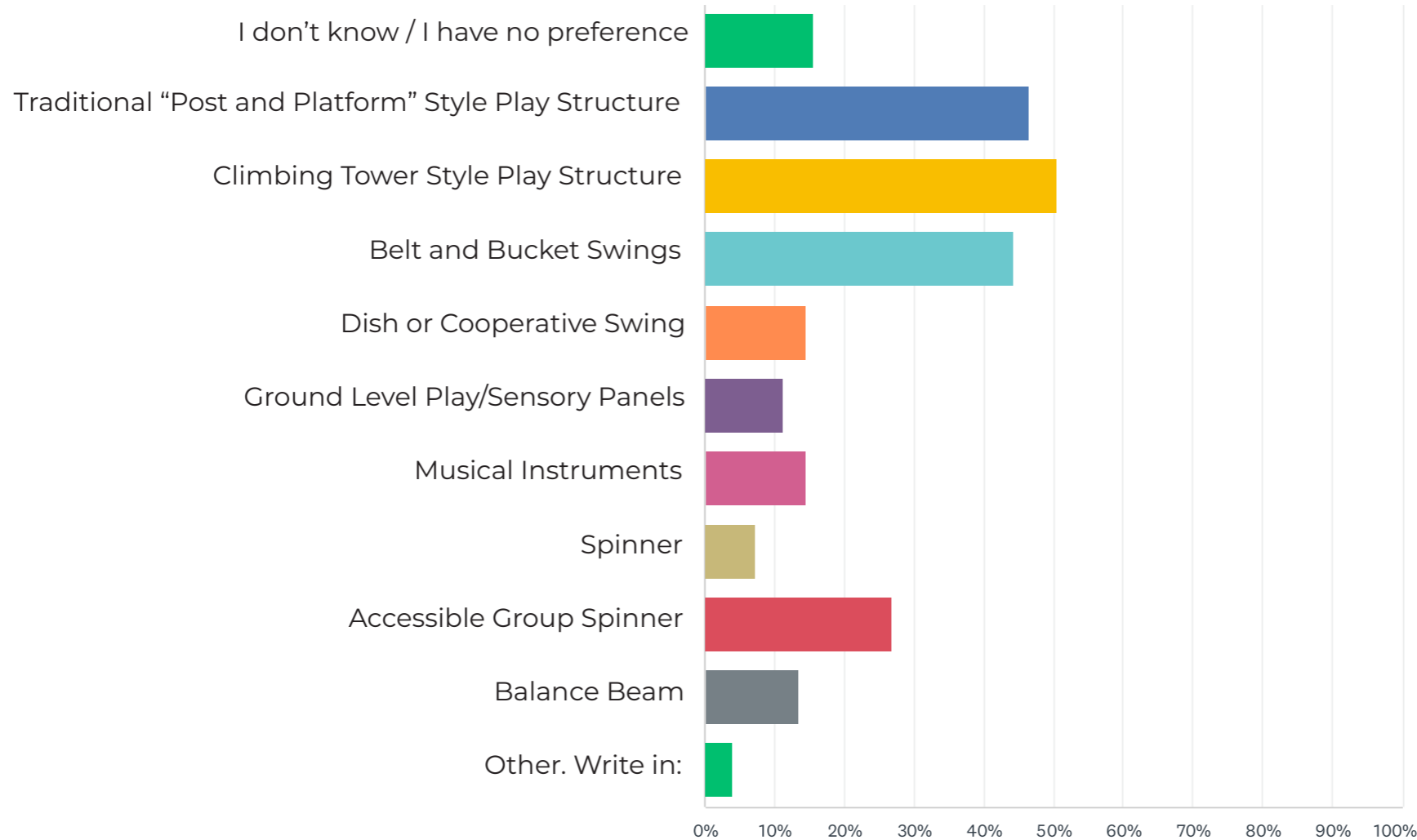

Priorities Summary: The **climbing tower play structure** was the most desired play structure style. **Traditional "post and platform" style play structure** was second and **belt and bucket swings** were the third most desired.

ONLINE SURVEY | PROPOSED PLAY AREA DESIGNS

14

votes



OPTION A

"I like two entryways and that the playground is adjacent to the water play."

"I like the playground location and water play and option for picnic lawn as designed"

"Keeping the splash pad close to play area is important"

21

votes



OPTION B

"I like two entryways and that the playground is adjacent to the water play."

"I like having 2 main entry ways into the park from Faneuil St"

"playground and splash pad seem separate which is nice when you don't want the kids to get wet"

32

votes



OPTION C

"centered location of playground and splash pad at the entry plaza"

"tree cover is good in the summer time and the splashpad/ playground are grouped in one region"

"it shelters the playground from the road and allows for a nice shaded picnic area"

ONLINE SURVEY | SPLASHPAD

QUESTION: **The city intends to build a water play area (splash pad) at McKinney Playground. What features do you prefer?**

Answered: 97 Skipped: 0

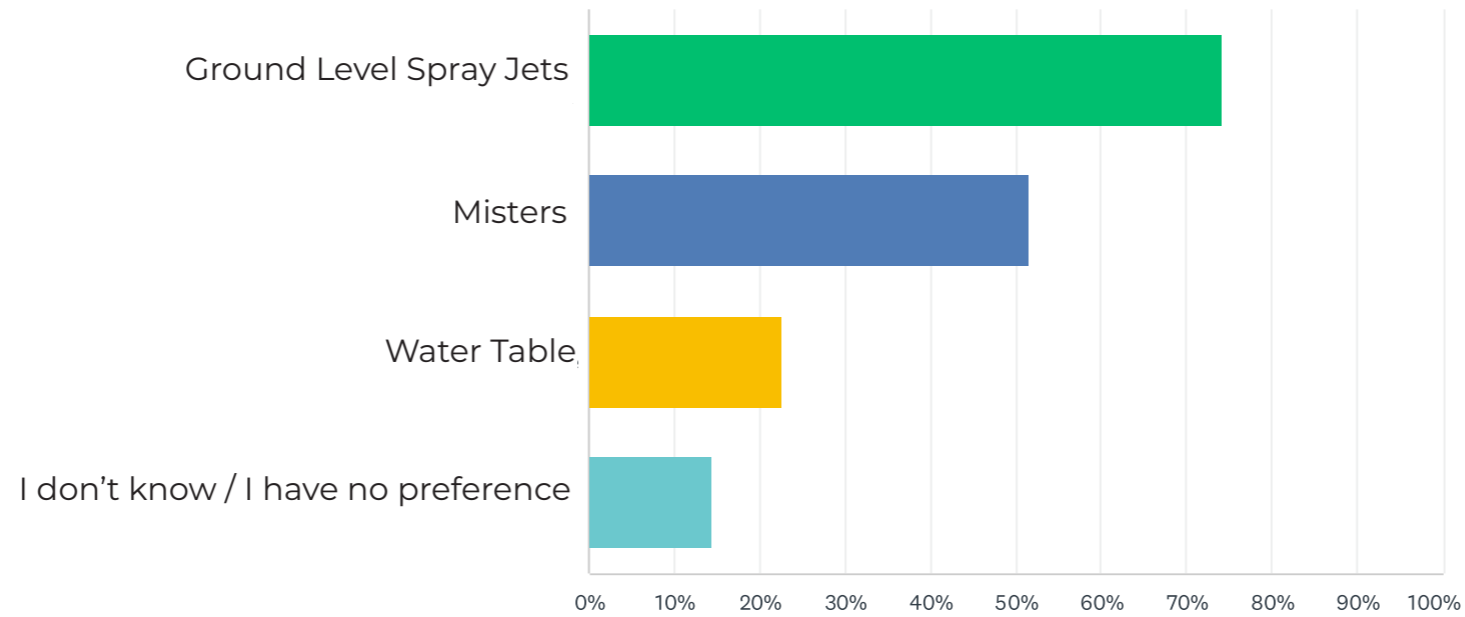

Priorities Summary:
Ground-level spray jets
were most preferred.



ONLINE SURVEY | SITE AMENITIES

QUESTION: **What are your highest priority site amenities for Mckinney Playground?**

Answered: 97 Skipped: 0

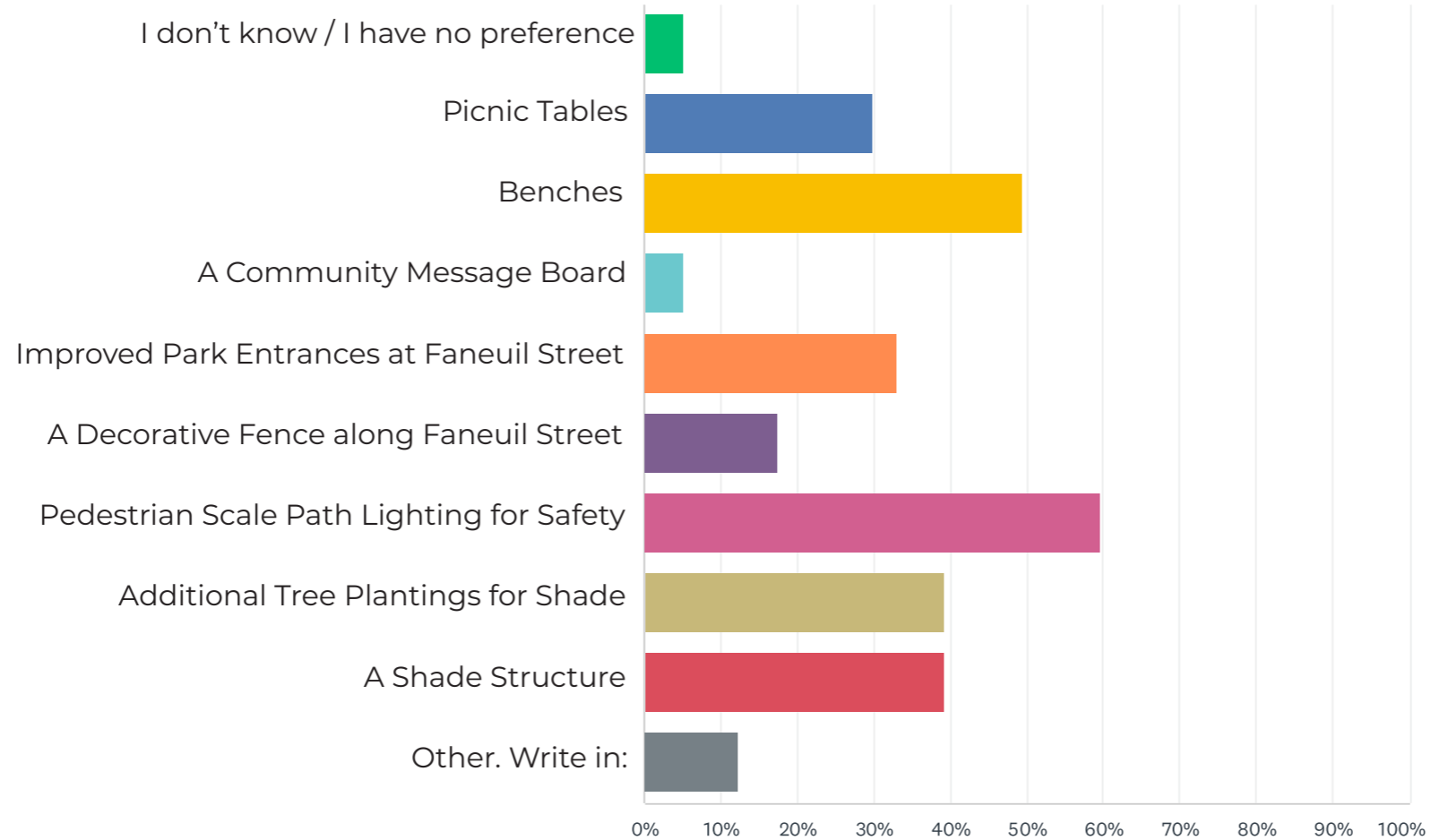

Priorities Summary:
Pedestrian Scale Path Lighting for Safety was the highest priority site amenities, followed by **Benches**. **Additional Tree Plantings for Shade** and **Shade Structure** were tied for third.

ONLINE SURVEY | PARK ENTRANCES

QUESTION: **Which entrance to the park do you use?**

Answered: 87 Skipped: 10

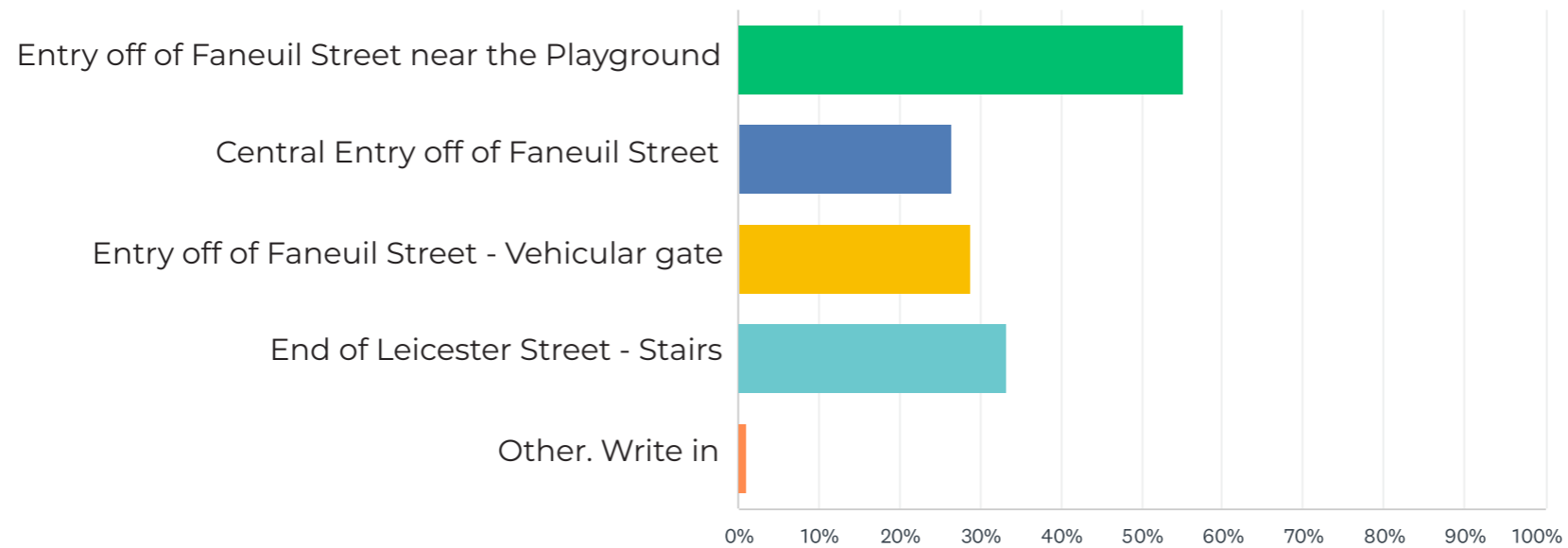

Priorities Summary: **Entry off Faneuil Street near the playground (closest to Goodenough Street)** was the most used.



PROPOSED SCHEMATIC PLAN



PROPOSED SCHEMATIC PLAN

Natural Turf Little League, Baseball, and Soccer Fields



SOCCER FIELD LAYOUT | NATURAL TURF



1X U13+/MIAA Field (66x110 yards) does not fit with infields.



1X U11/12 Field (45x70 yards min) and 1X U10 Field (35x55 yards min.)



2X U10 Fields (35x55 yards min.)



10X U8 Fields (15x25 yards min.)

MATERIALS | SPORTS FIELD SITE ELEMENTS



MATERIALS | ADULT EXERCISE EQUIPMENT



FIELDS | IMPROVED DRAINAGE: TOPOGRAPHY

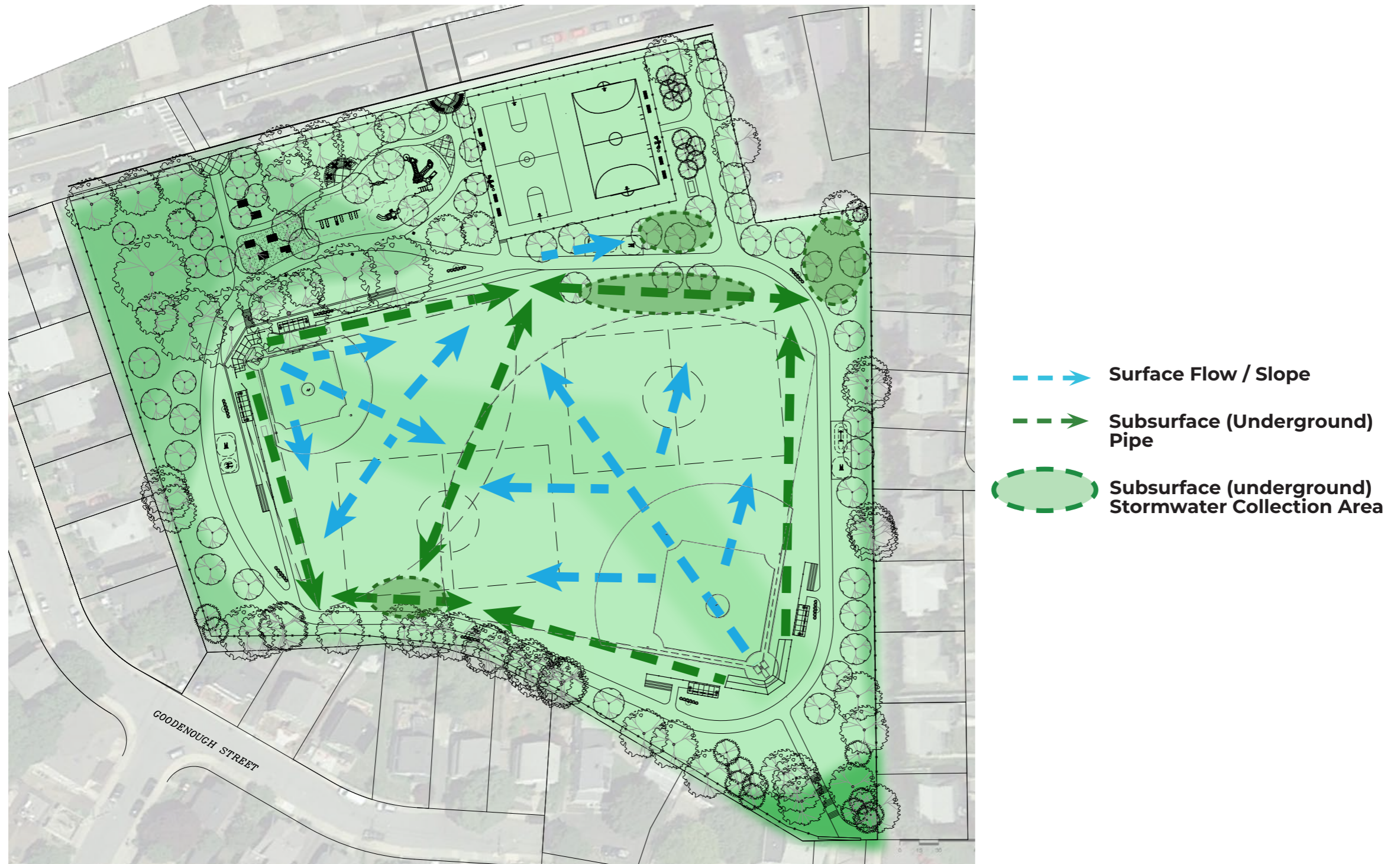

Prior to the final design, the topography in the field area will be thoroughly analyzed so that the final condition will direct stormwater away from use areas. Additionally, subsurface stormwater piping and storage will likely be needed to reduce water lingering at the surface, which can cause soggy and compacted fields.

FIELDS | IMPROVED DRAINAGE: SECTION

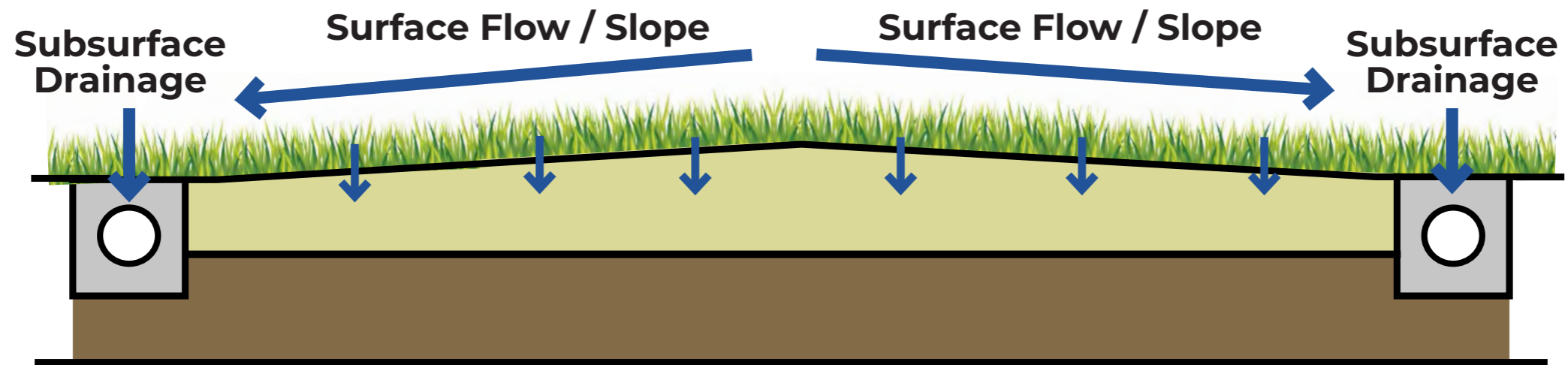

FIELDS | IMPROVED DRAINAGE: GRASS





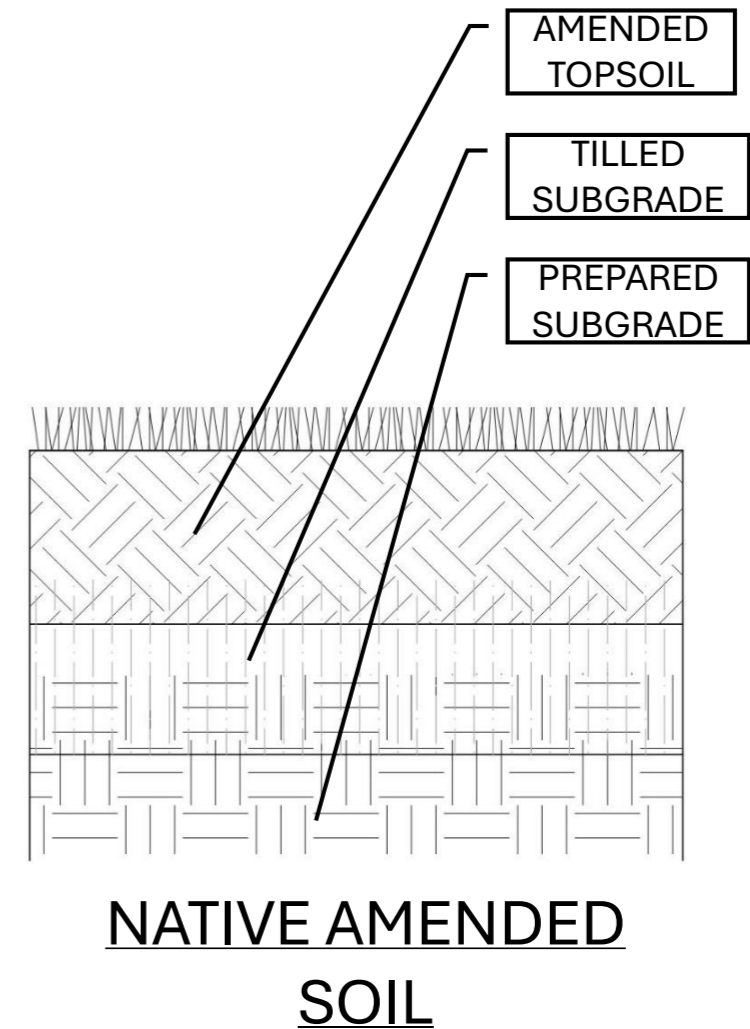

Native, drought tolerant grass species will be specified to withstand heavy use, and also to succeed without intensive maintenance, such as irrigation or frequent fertilizer applications and/or aeration.

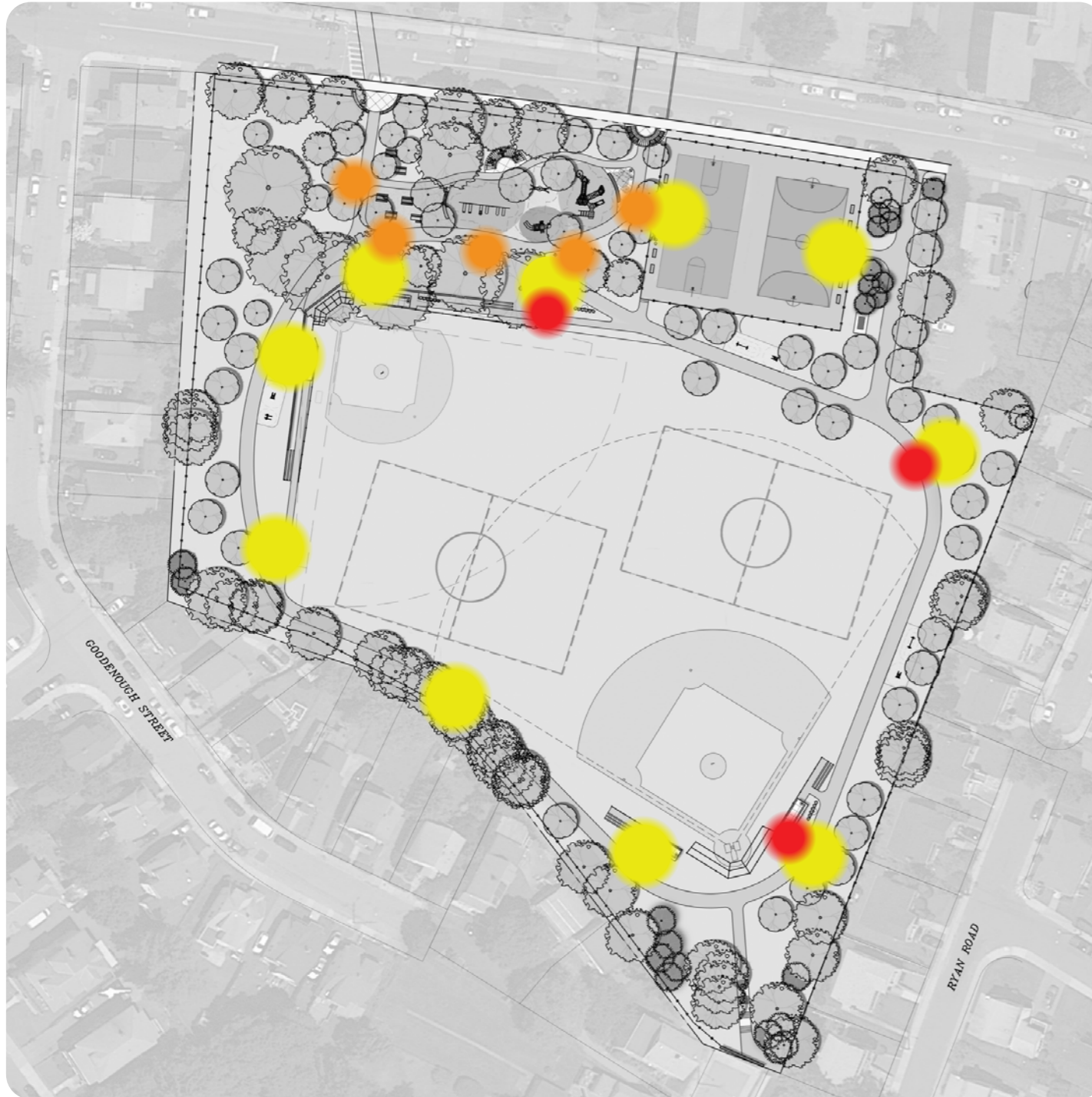

Prior to the final design, the existing soils in the field area will be thoroughly analyzed so that in the final condition the soil can accept stormwater. Subsurface stormwater storage may be needed to reduce water lingering at the surface, which can cause soggy and compacted fields.

MATERIALS | LIGHTING



TYPE	TIMING	OWNER/ OPERATOR
 Sports Light	Only on During Permitting Use	Boston Parks & Recreation Department (BPRD)
 Pedestrian Scale Path Lights on Sports Light Poles	6PM-Midnight, or as Determined by the Community	Boston Parks & Recreation Department (BPRD)
 Pedestrian Scale Path Lights	Dusk-Dawn	Boston Street Lighting Department (BSL)

MATERIALS | PEDESTRIAN LIGHTING



CBA Landscape Architects

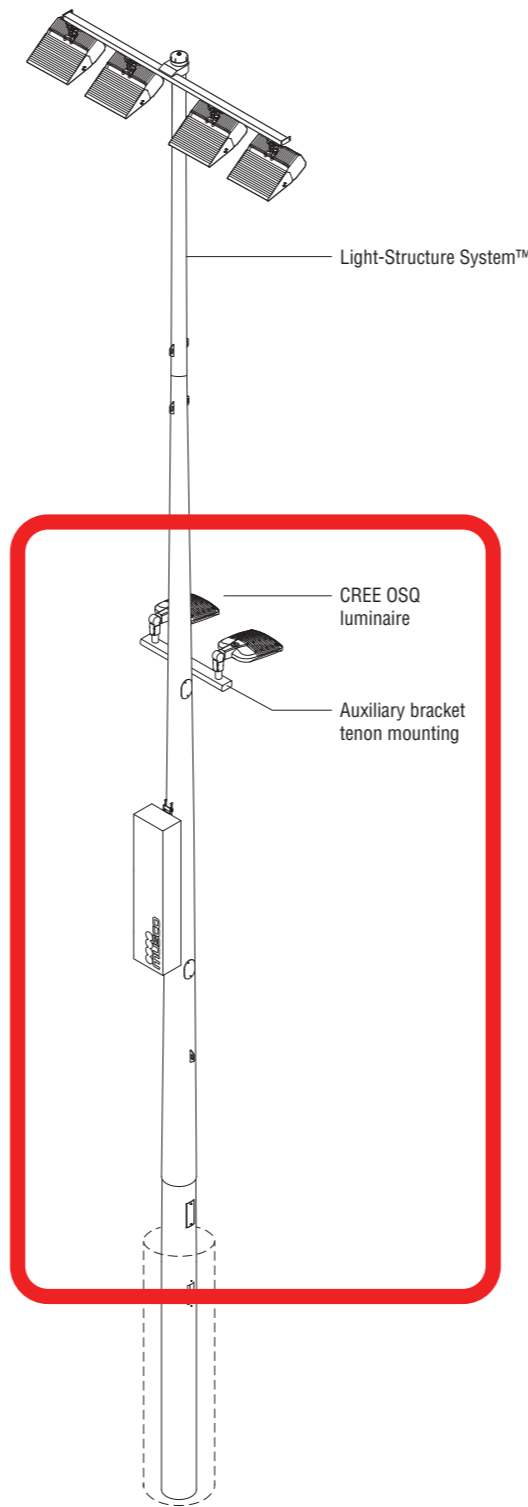

Luminaire Data

Manufacturer	Cree, Inc.
Material and finish	Die-cast aluminum with silver powder-coat finish ⁴
Mounting	Adjustable arm on 2.38 in (60mm) O.D. tenon
Pole attachment	Auxiliary bracket mount
Weight (luminaire)	26.5 lb (12kg)

Regulatory and Voluntary Qualifications

UL	cULus Listed
Environment	Suitable for wet locations
DLC qualified	See www.designlights.org/QPL
Ingress Protection	IP66
Emissions	Meets FCC Part 15, Subpart B, Class A standards for conducted and radiated emissions
RoHS	Compliant

Photometric Characteristics

Lumen maintenance factor ¹	
25k hours ²	0.95
50k hours ²	0.9
75k hours ²	0.85
100k hours ³	0.81
CIE correlated color temperature	5700 K
Color Rendering Index (CRI), minimum	70
Lumens	17,000

Footnotes:

- 1) Lumen maintenance values at 25° C ambient temperature are calculated per TM-21 based on LM-80 data and in-situ luminaire testing.
- 2) Values are represented as projected values within six times limit of tested hours per IES TM-21-11.
- 3) Values are represented as calculated values due to exceeding six times limit of tested hours.
- 4) Cree's exclusive Colorfast DeltaGuard® finish features an E-coat epoxy primer with an ultra-durable powder topcoat, providing excellent resistance to corrosion, ultraviolet degradation, and abrasion.

Typical Boston Parks Pedestrian Pole Light (Left);
Pedestrian Light Fixture Installed on Sports Light Pole (Right)

What Matters in Lighting Technology

Light Control

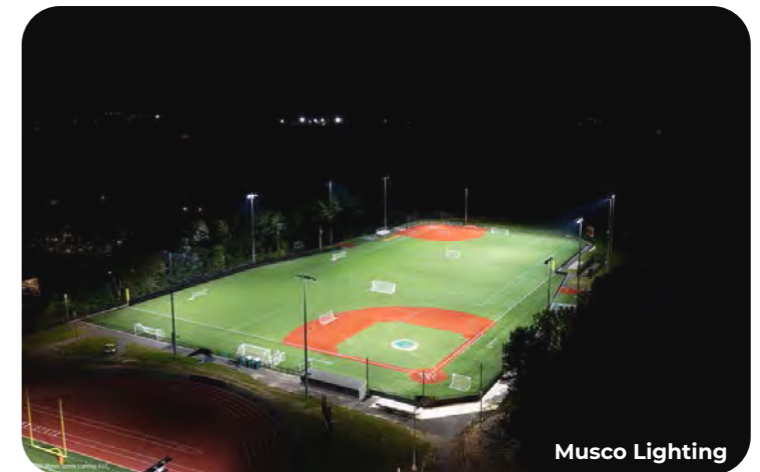
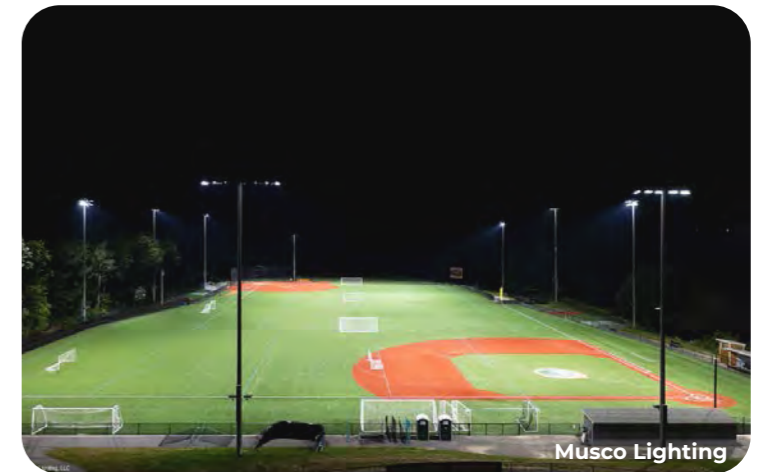
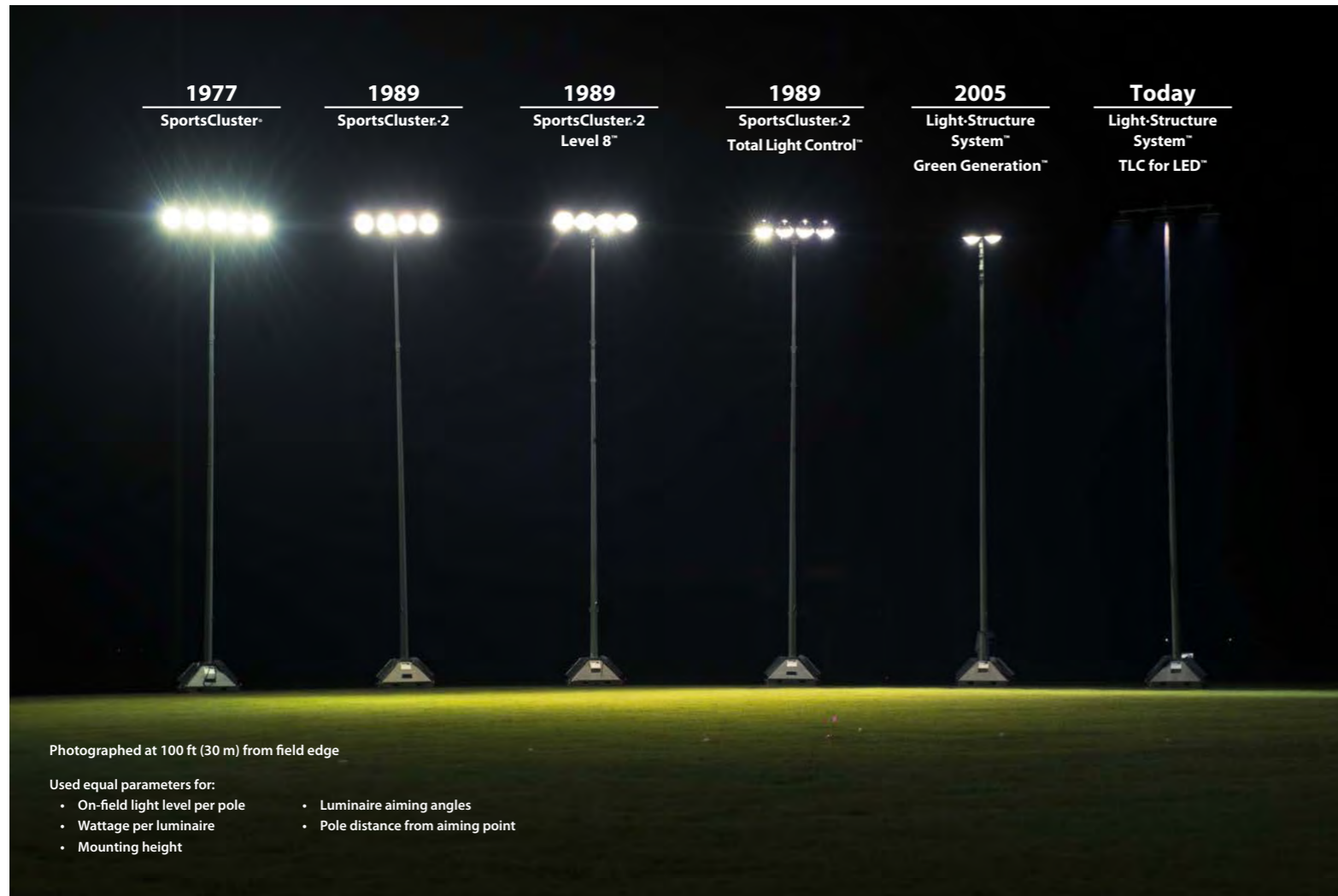

©2015, 2017 Musco Sports Lighting, LLC - M-1905-en04-4



Solutions for Lighting



Boston College LED field lights at the Brighton Campus.

City of Boston Total Light Control Installations:

- **Cassidy Playground**
- **Smith Playground**
- **Boston College (Brighton)**
- Carter Playground,
- DeFilippo Playground,
- Doherty-Gibson Playground,
- East Boston Stadium,
- Garvey Playground,
- Harambee Park,
- Langone Park,
- Madison Park,
- Malcolm X Park,
- McConnell Park,
- Noyes Park,
- Ramsay Park,
- Reservation Road Park,
- Ronan Park,
- Rotch Playground,
- South Street Courts

PROPOSED PLAY AREA | ONLINE SURVEY

14

votes



OPTION A

“I like two entryways and that the playground is adjacent to the water play.”

“I like the playground location and water play and option for picnic lawn as designed”

“Keeping the splash pad close to play area is important”

21

votes



OPTION B

“I like two entryways and that the playground is adjacent to the water play.”

“I like having 2 main entry ways into the park from Faneuil St”

“playground and splash pad seem separate which is nice when you don’t want the kids to get wet”

32

votes



OPTION C

“centered location of playground and splash pad at the entry plaza”

“tree cover is good in the summer time and the splashpad/ playground are grouped in one region”

“it shelters the playground from the road and allows for a nice shaded picnic area”

PROPOSED PLAY AREA | OPTION C REFINED

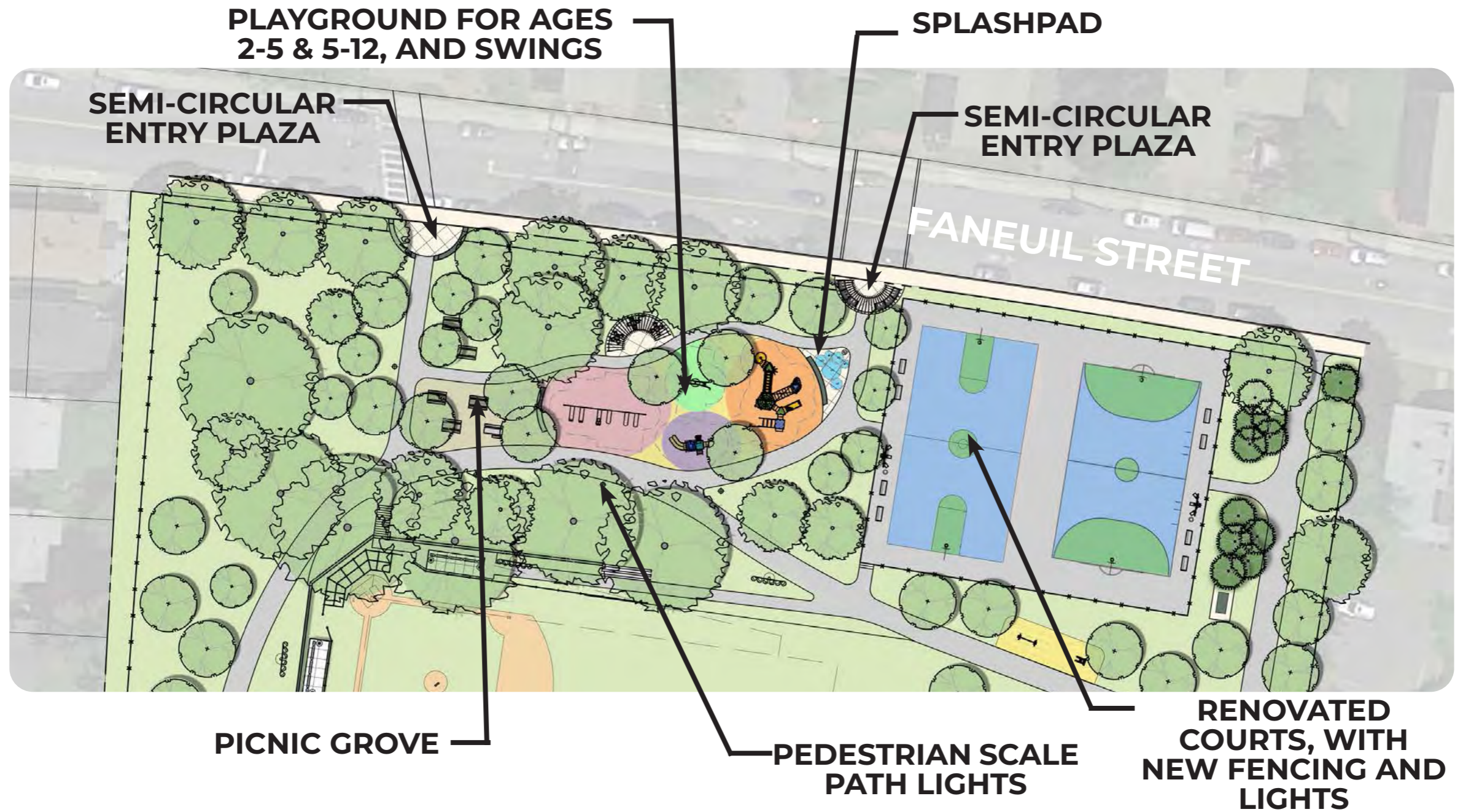

FANEUIL GARDENS CROSSWALK COORDINATION

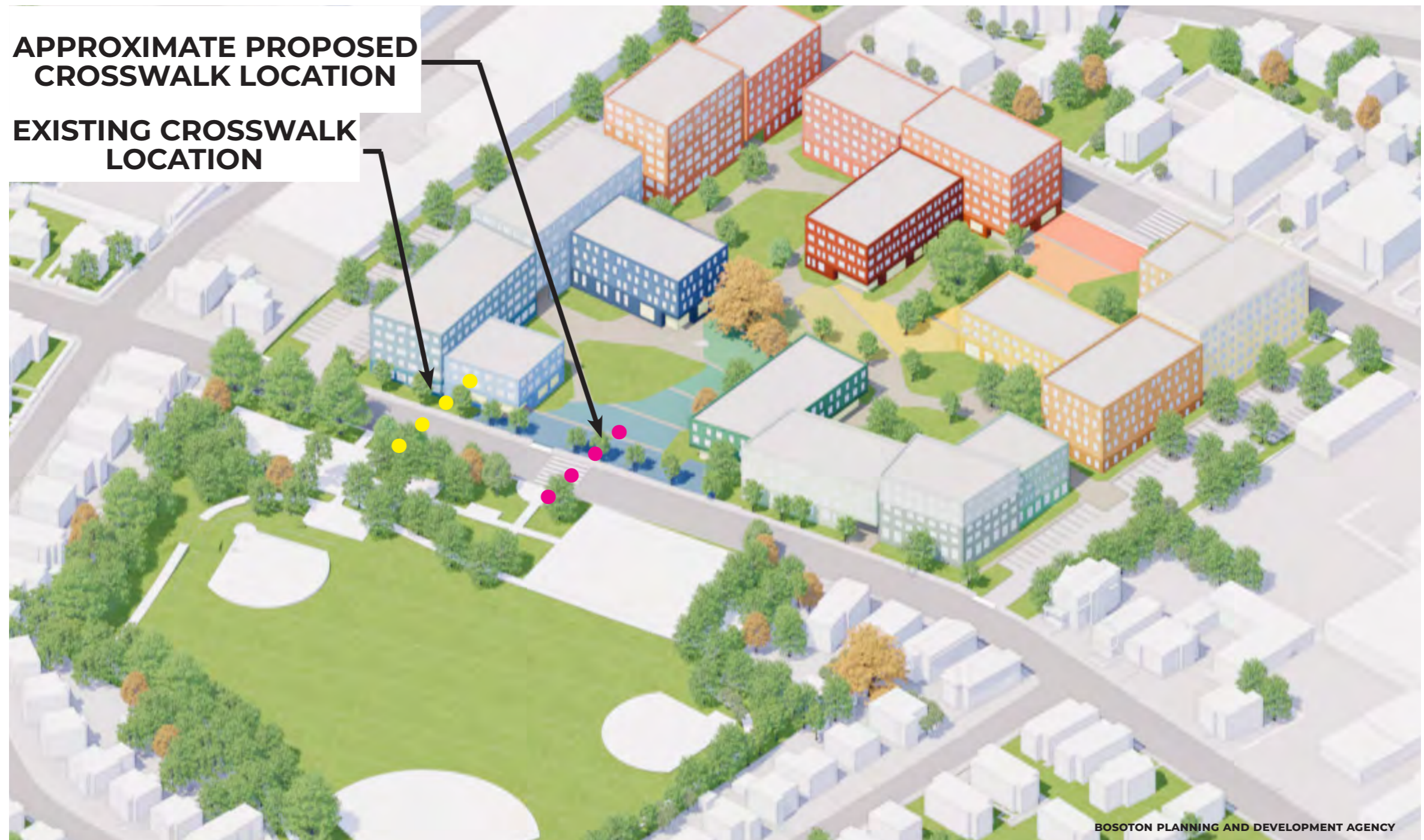

The Boston Housing Authority is developing a major renovation of the Faneuil Gardens Housing. The timeline is expected to be phased over several years. **The renovation includes the relocation and redesign of the pedestrian crosswalk that connects Faneuil Gardens and McKinney Playground.** The McKinney Playground design team is working to create a welcoming park entry at the new crosswalk.

MATERIALS | PARK ENTRIES

Pergola Shade Structure & Columns



MATERIALS | SHADE

Shade Trees, Shade Structure, & Team Bench (Dugout) Shelters



MATERIALS | FURNITURE

Benches, Picnic Tables, Game Tables, Trash Receptacles, & Bike Racks

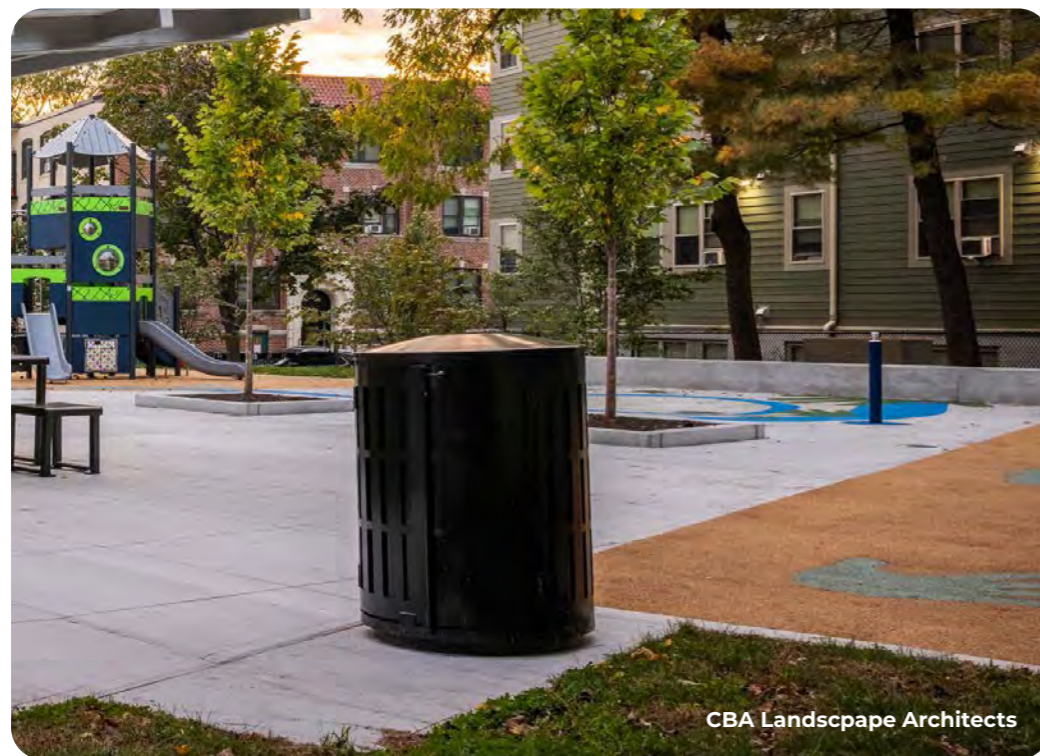

MATERIALS | PLAYGROUNDS - AGES 2-5

Post & Platform Style
Play Structure



Ed Wonek Art Works Inc.

MATERIALS | PLAYGROUNDS - AGES 5-12

Climbing Tower Style
Play Structure



Landscape Structures, Inc.

MATERIALS | PLAYGROUNDS - SWINGS

Traditional (Belt and Bucket) Swings, Adaptive Swing, & Dish Swings



MATERIALS | SPLASH PAD

Ground Level Spray Jets
with Painted Graphics





LISTENING & DISCUSSION

Help us build great parks.
Let us know what matters to you.

THANK YOU!

Nelle Ward, Project Manager
Boston Parks and Recreation
Nelle.Ward@boston.gov

For questions, maintenance requests or
concerns regarding any of our
parks contact 311

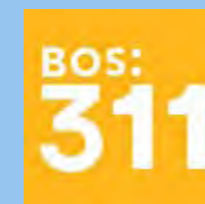

June 4, 2024
Boston Parks and Recreation

