

Sally's PIZZA

EXTERIOR MODIFICATIONS SUBMISSION
30 THOMSON PLACE ALLEY



DESIGN REVIEW TOPICS

LOCATION OF BUILDING WITHIN DISTRICT

EXISTING PHOTOS

PROPOSED ELEMENTS

- 30 THOMSON PLACE - EXISTING CONDITIONS
- 30 THOMSON PLACE - ARCHITECTURAL MODIFICATIONS
- 30 THOMSON PLACE – MECHANICAL DETAILS
- 30 THOMSON PLACE – ROOFTOP EQUIPMENT SIGHTLINES AND LAYOUT

NEIGHBORHOOD PHOTOS

HISTORIC PHOTOS

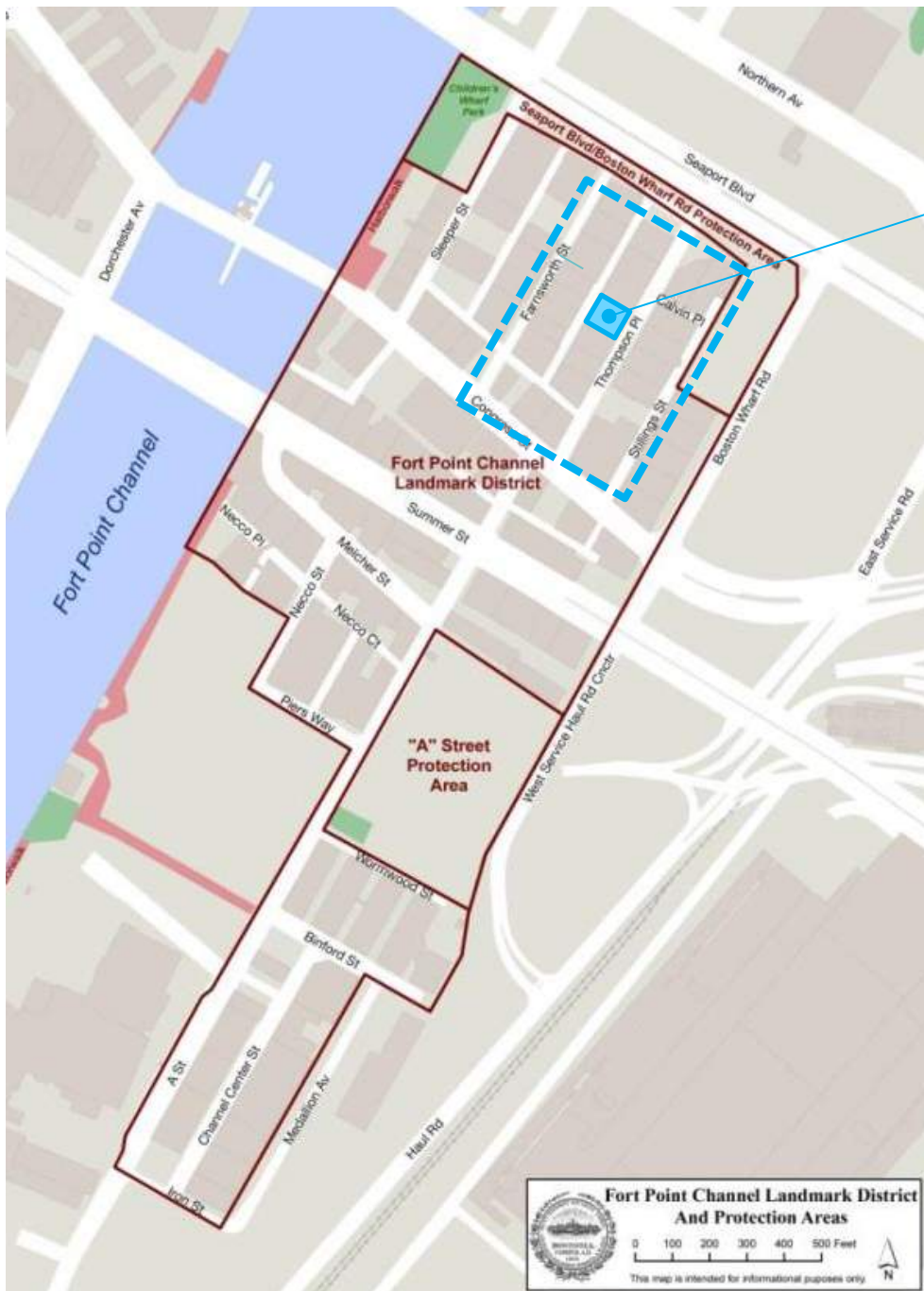

30 THOMSON PLACE

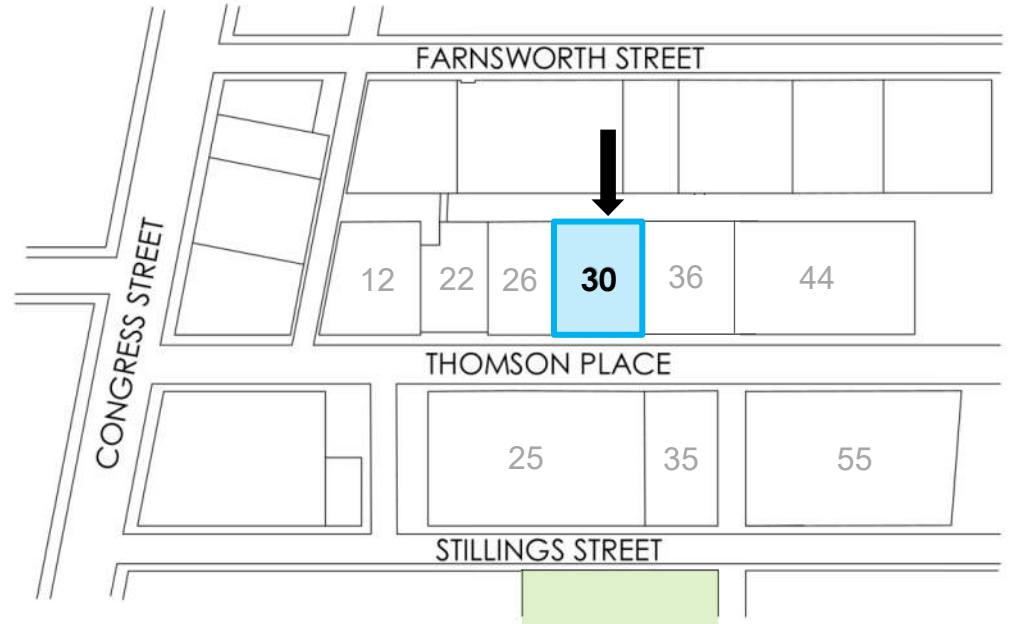

PROJECT LOCATION MAP

FORT POINT CHANNEL LANDMARK DISTRICT

12.14.2023





VIEW FROM LEFT CORNER



VIEW FROM RIGHT CORNER



PHOTO COMPILATION OF ELEVATION

EXISTING CONDITION PHOTOS

12.14.2023

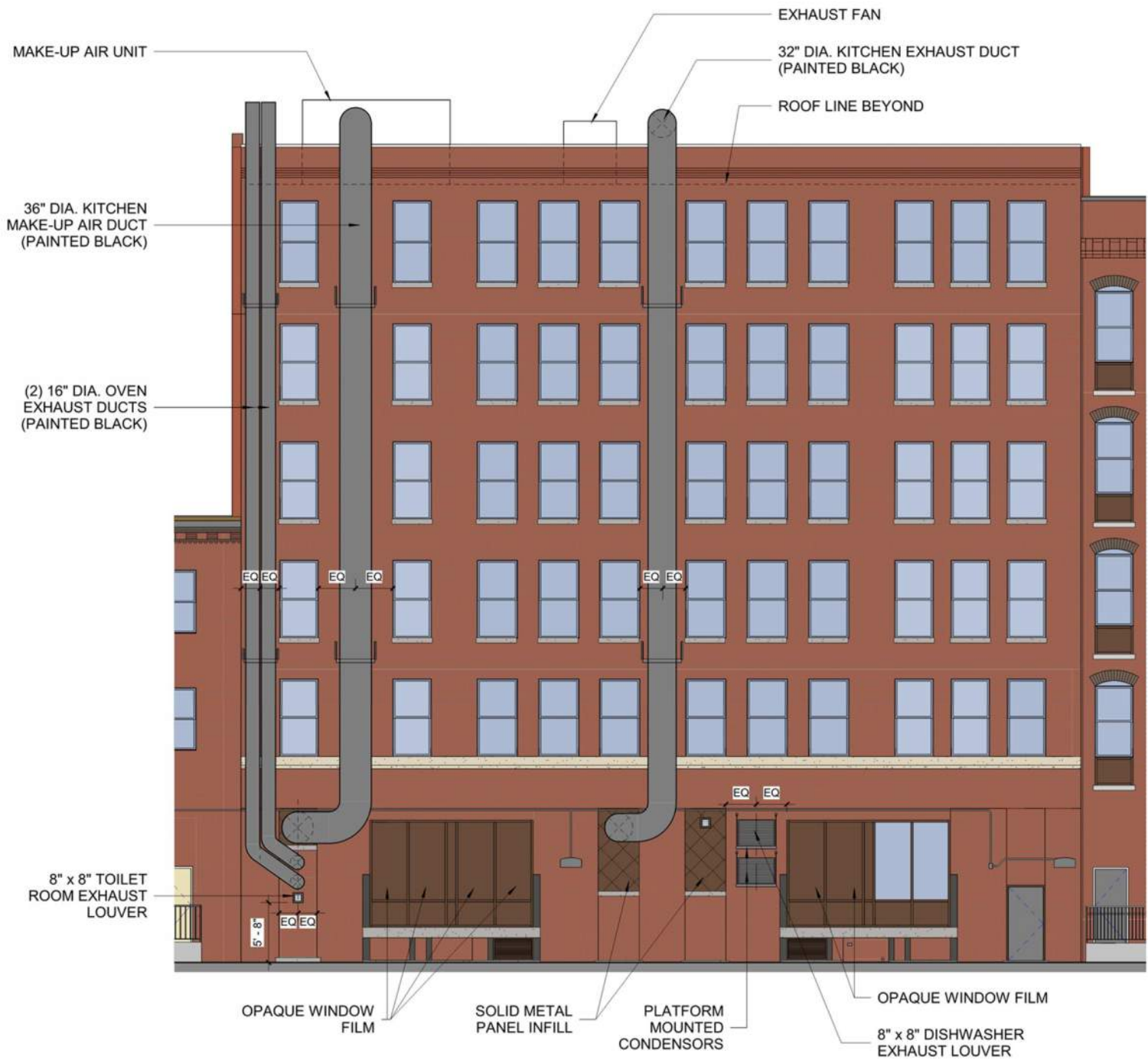

RENDERED ELEVATION OF PROPOSED CHANGES

12.14.2023



RENDERED ELEVATION OF MODIFICATIONS

12.14.2023

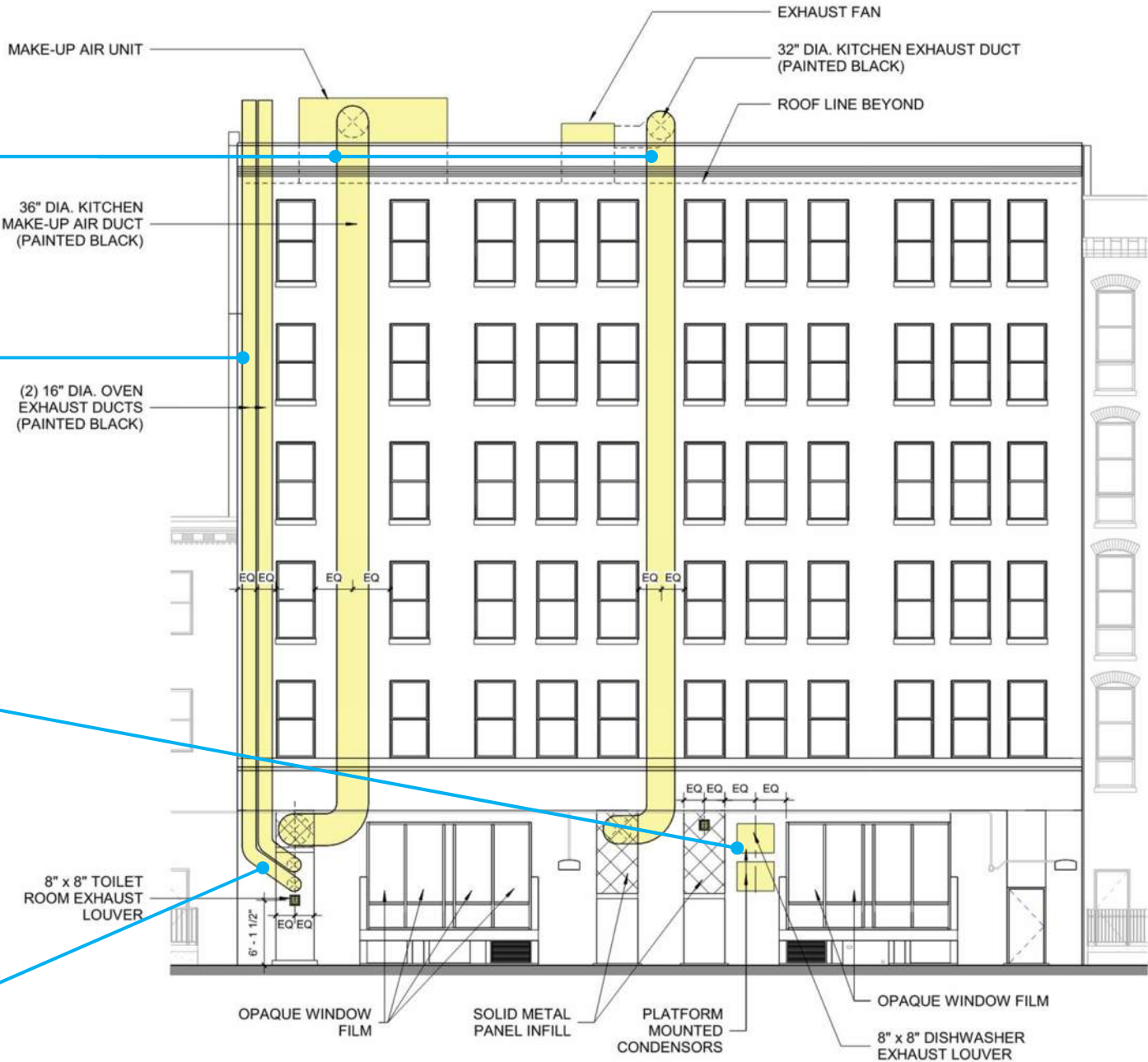
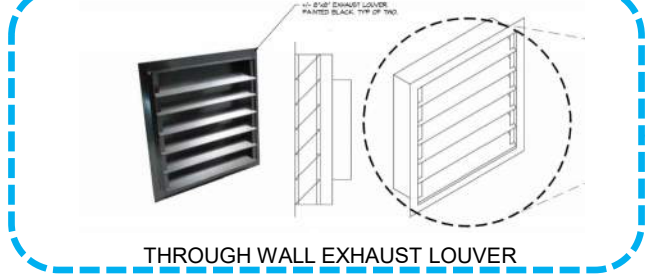
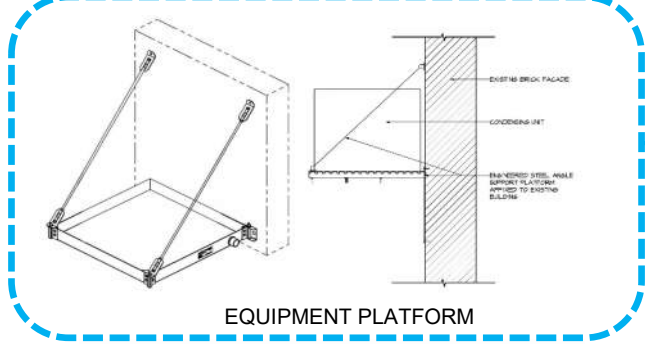
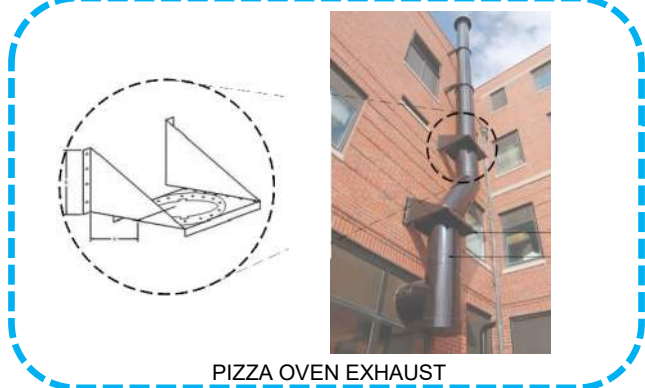
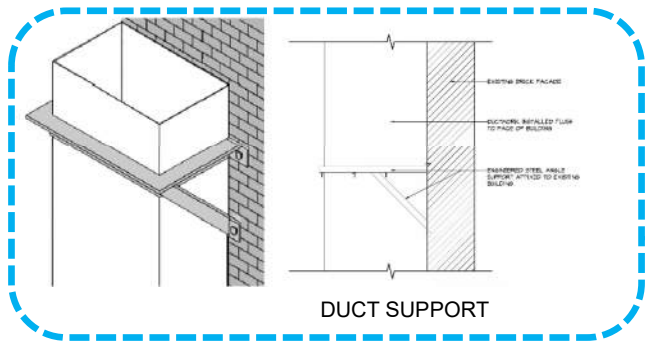

MECHANICAL DETAILS

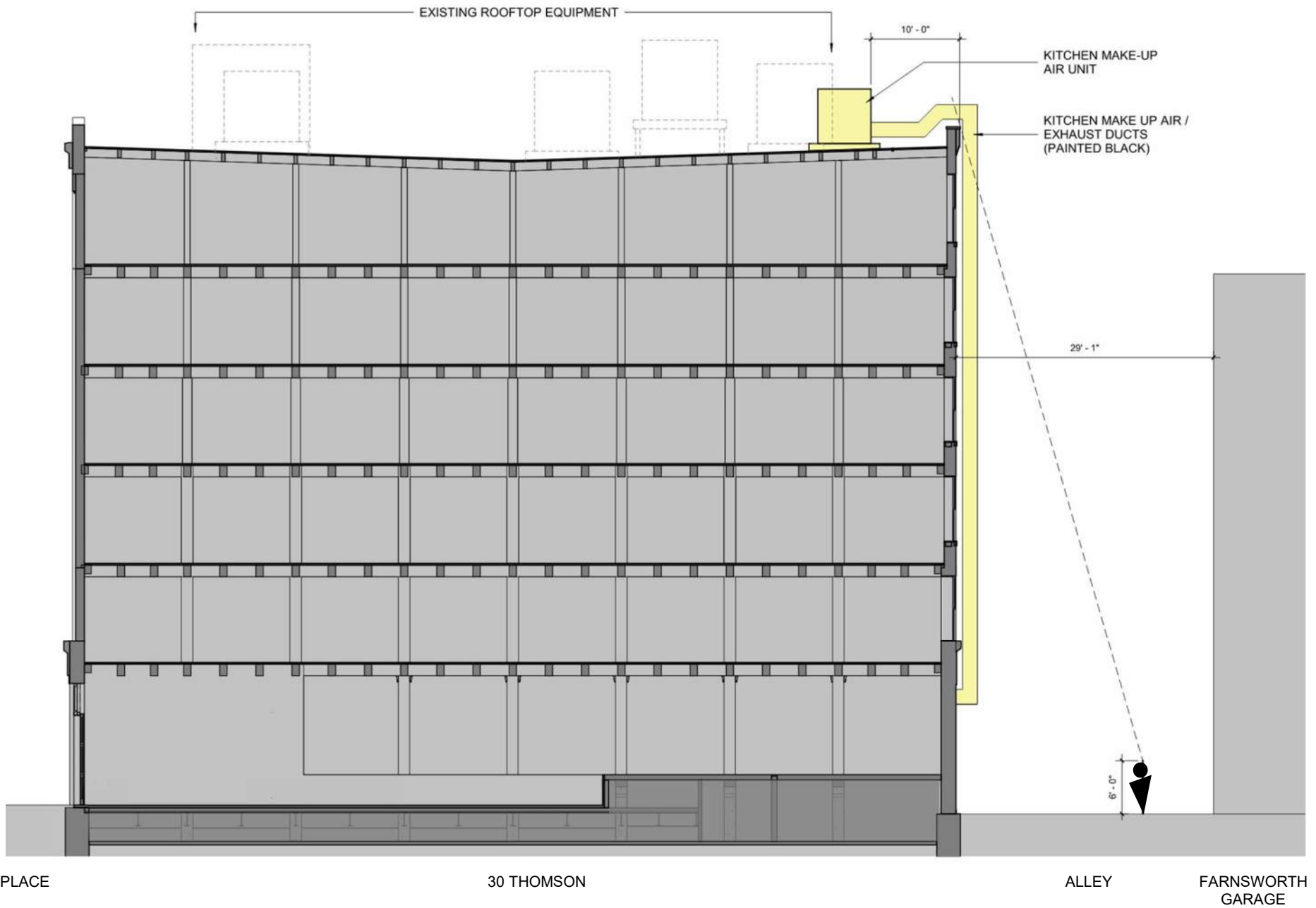

BUILDING CROSS SECTION SHOWING SIGHTLINES

12.14.2023

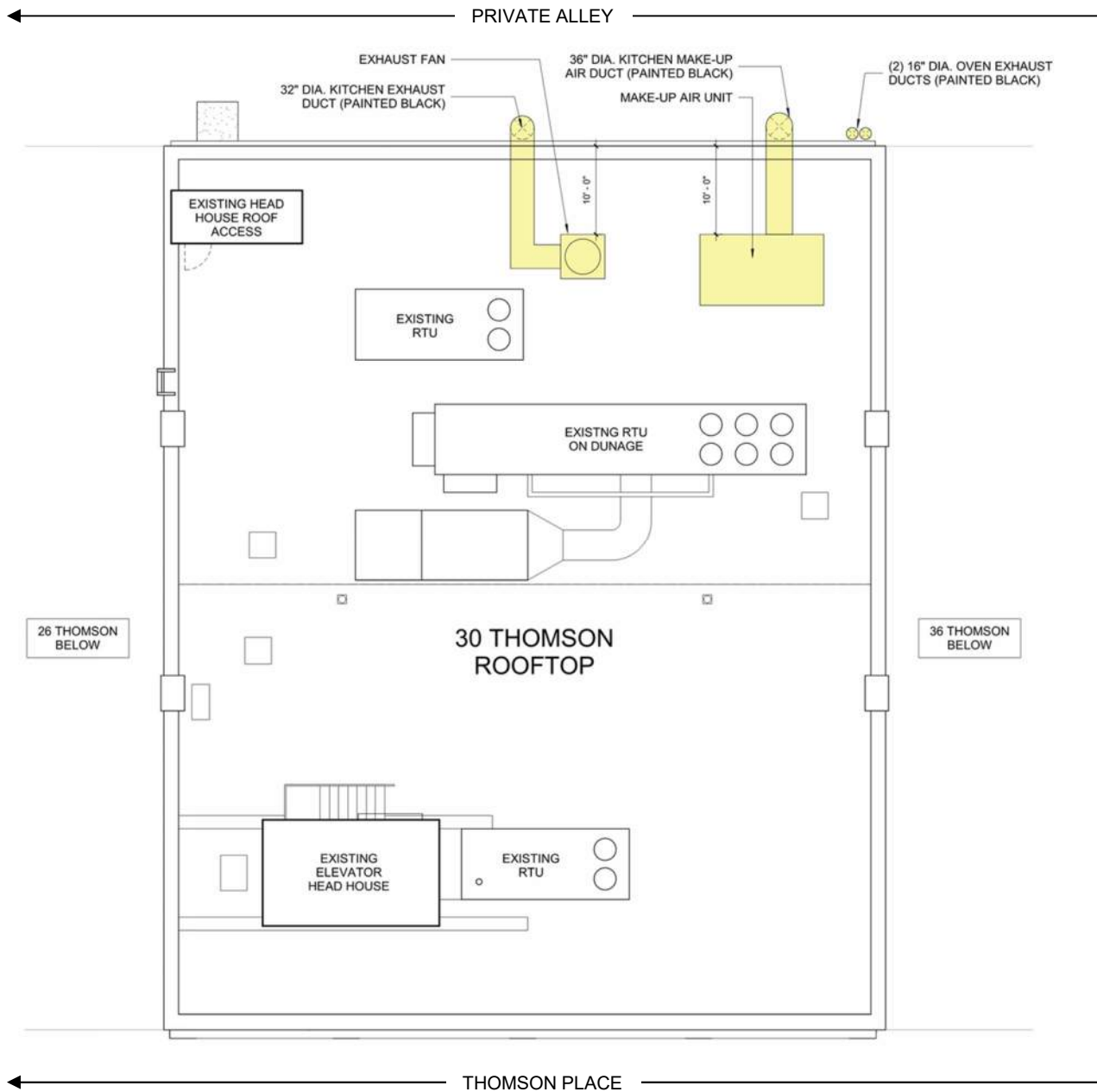

ROOFTOP EQUIPMENT PLAN

12.14.2023



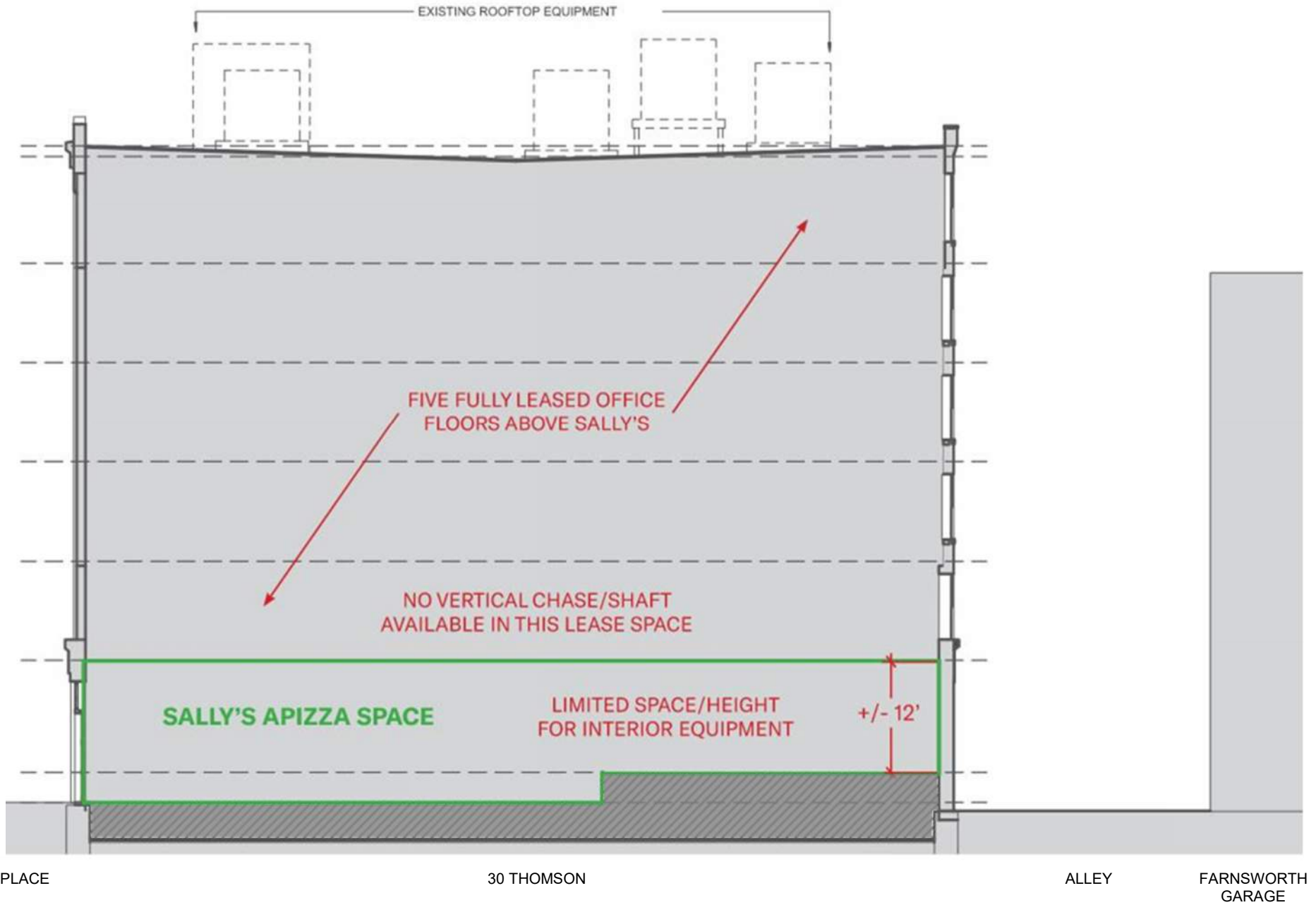

THOMSON PLACE

30 THOMSON

ALLEY

FARNSWORTH
GARAGE

BUILDING CROSS SECTION SHOWING SIGHTLINES

12.14.2023

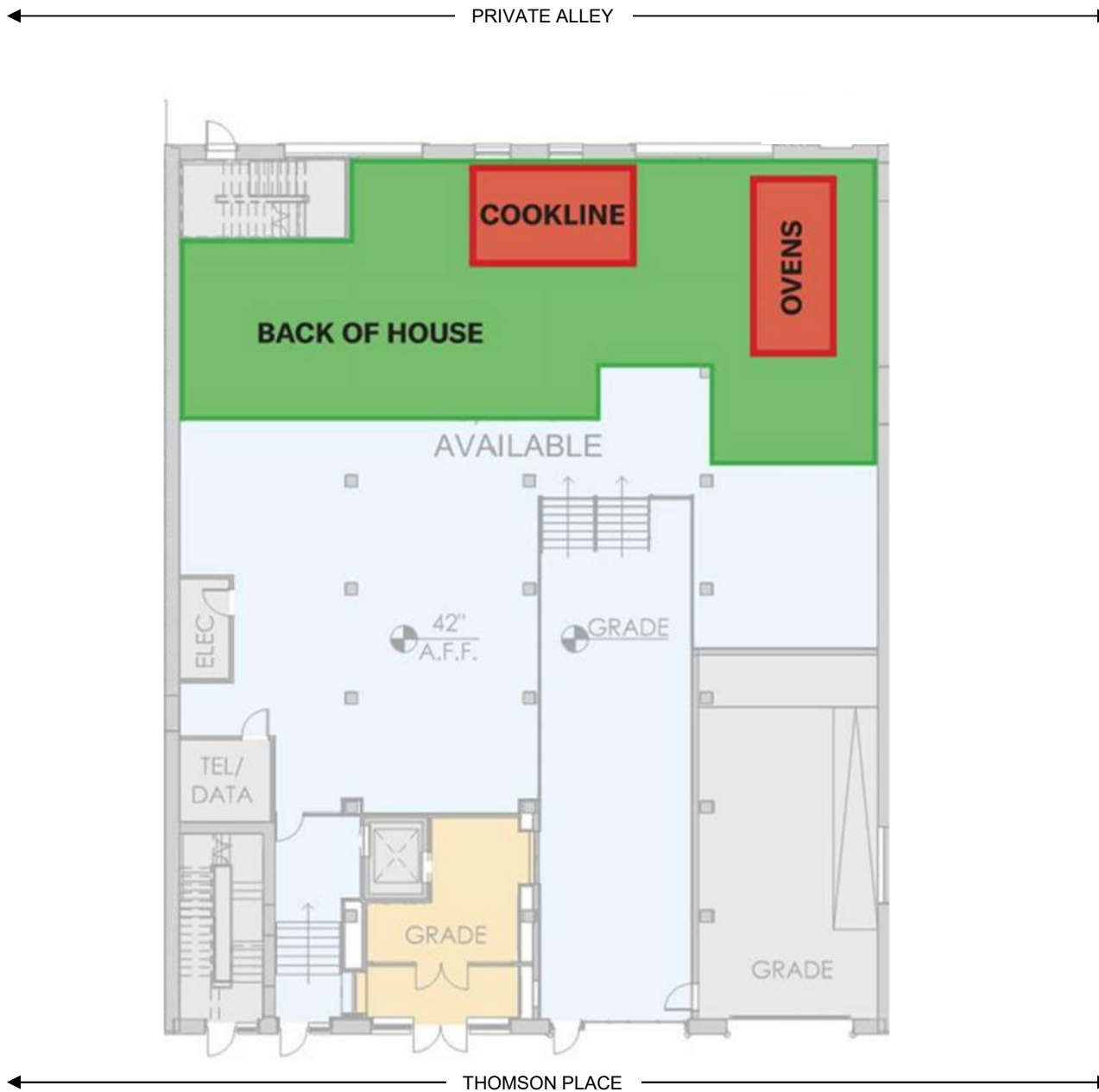

BUILDING CROSS SECTION SHOWING SIGHTLINES

12.14.2023



SURFACE MOUNTED DUCTWORK BEHIND "METRO" SPACE



SURFACE MOUNTED DUCTWORK BEHIND "LUCKY'S"

NEIGHBORHOOD PHOTOS OF DUCTWORK EXAMPLES

12.14.2023



CONDENSERS BEHIND 343 CONGRESS STREET

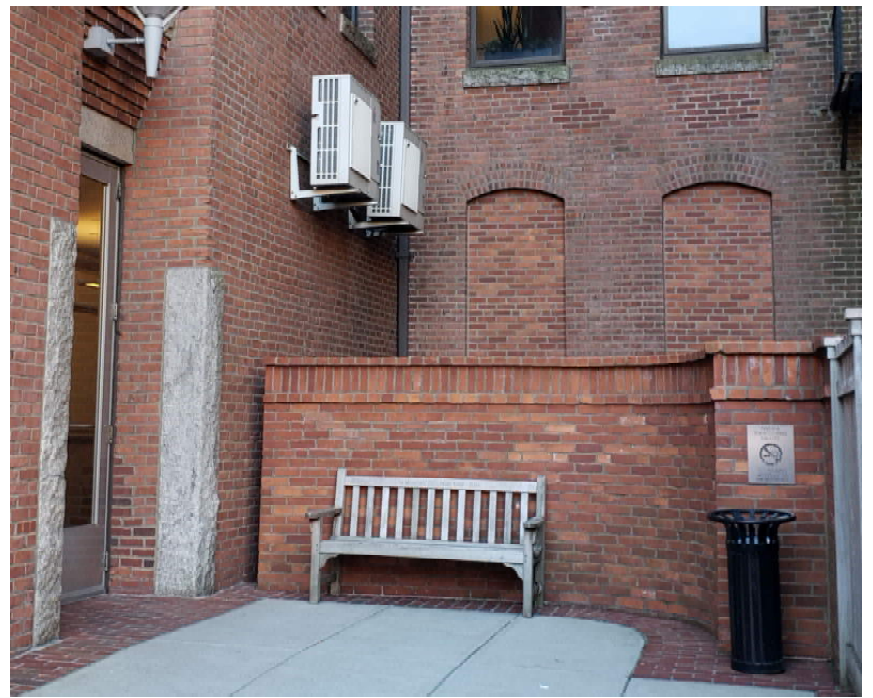

CONDENSERS BEHIND 274 SUMMER STREET



CONDENSERS BEHIND 281-283 SUMMER STREET

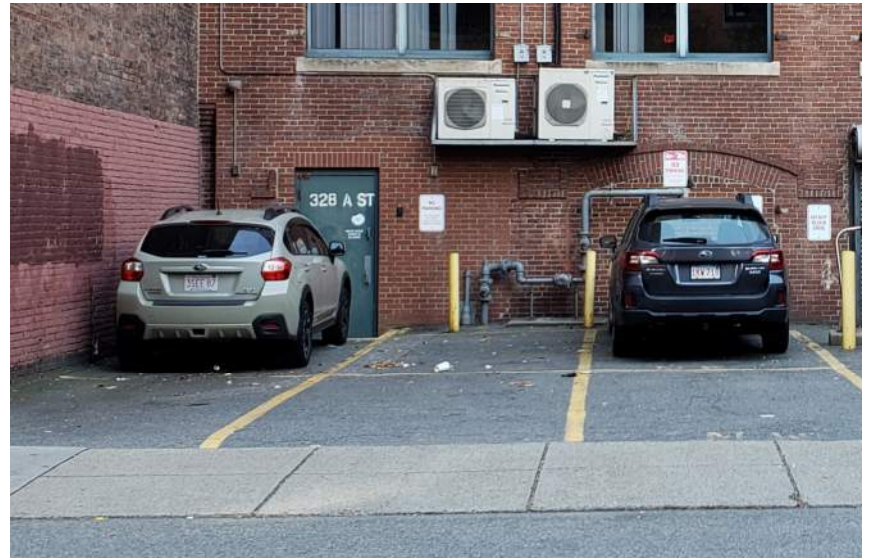

CONDENSERS AT 328 STREET

NEIGHBORHOOD PHOTOS OF WALL MOUNTED EQUIPMENT

12.14.2023

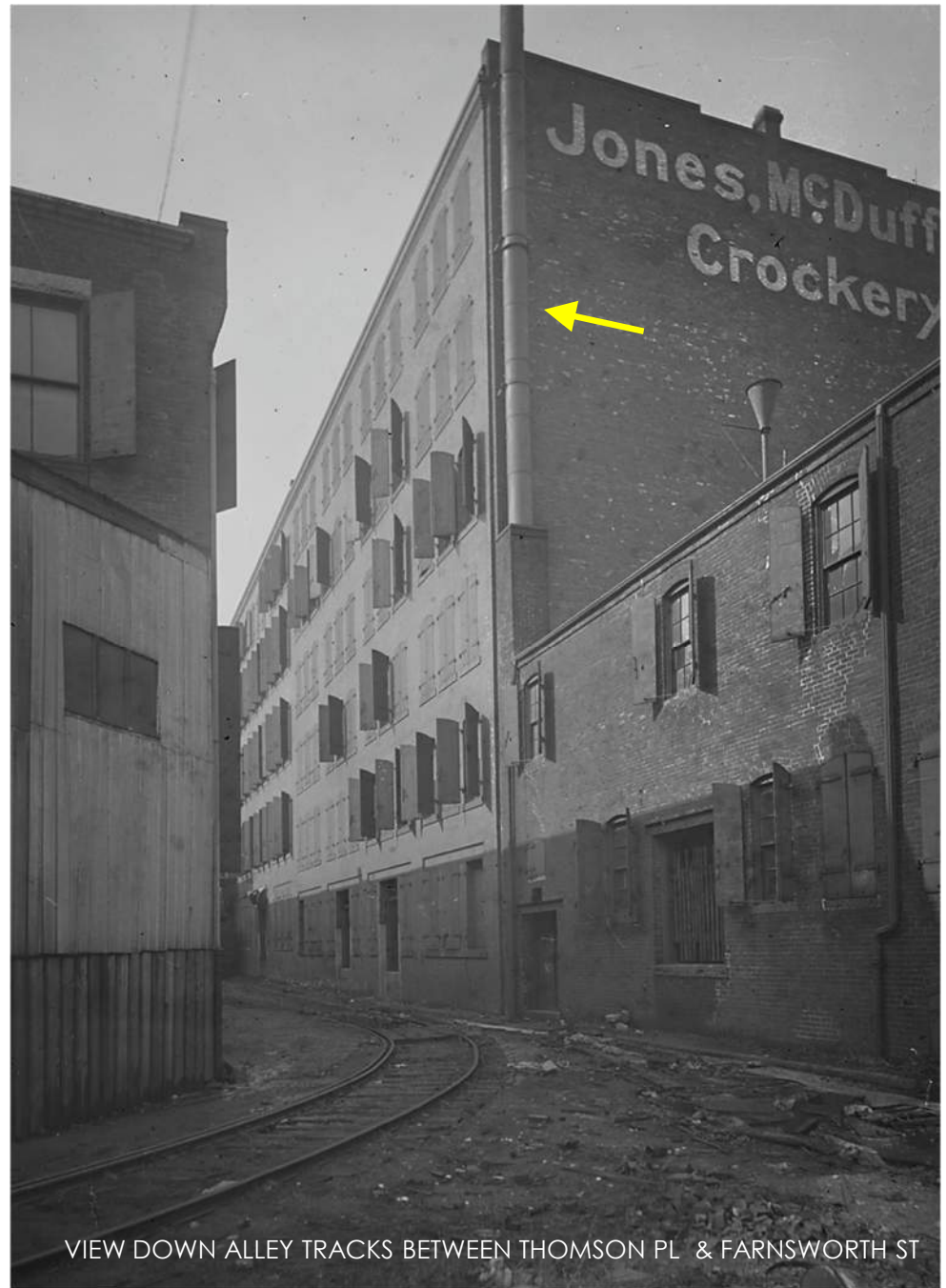
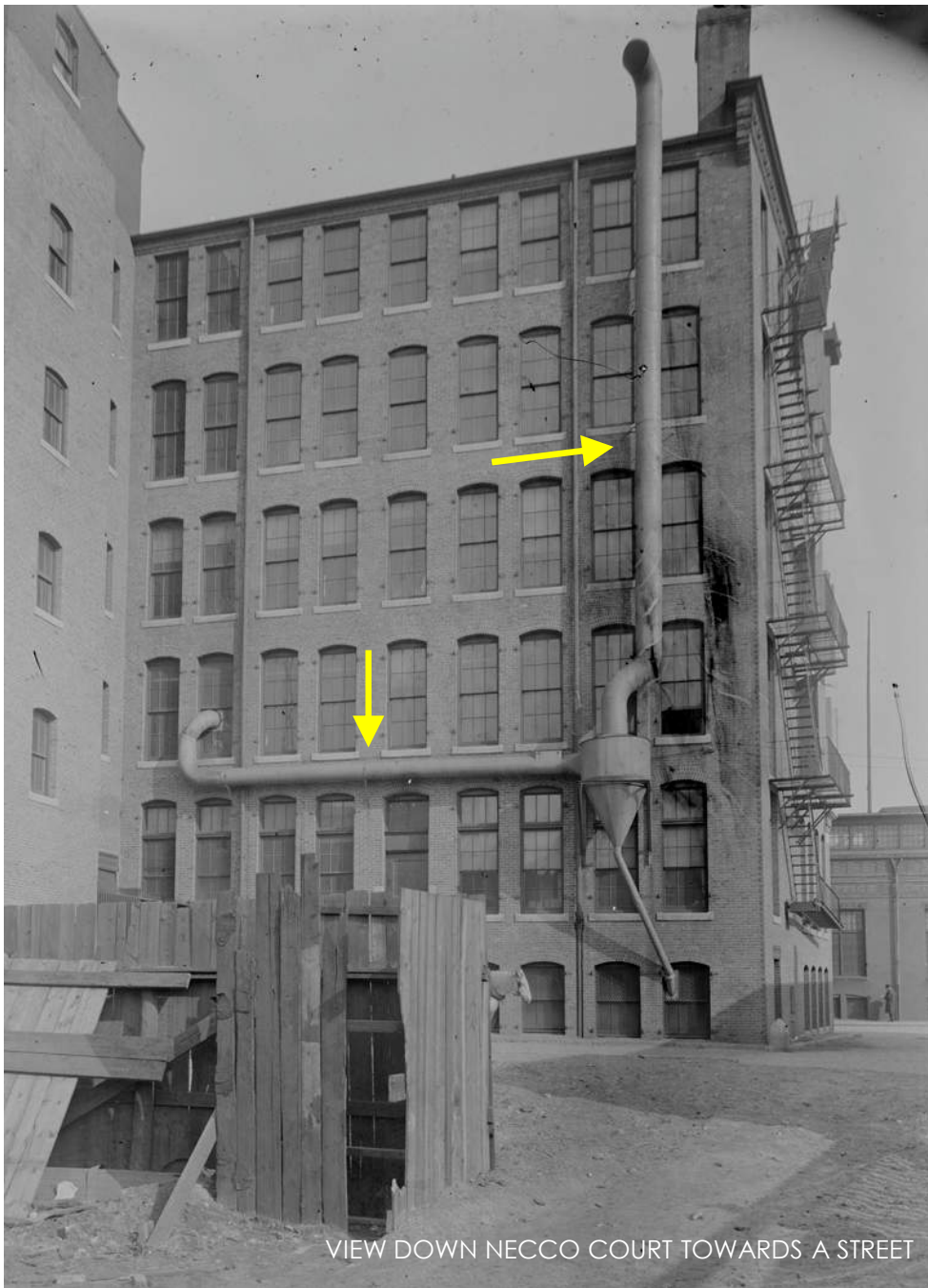

HISTORIC PHOTOS OF VENT STACKS FOR REFERENCE

12.14.2023

Sally's **PIZZA**

THANK YOU