

CHARLES ST DENTAL

121 Charles St South,
Boston, MA 02116

SQUARE FEET

SIGN
1

CHARLES ST DENTAL

14.38

SIGN
2

CHARLES
STREET
DENTAL

2.25

CHARLES ST DENTAL

Address 121 Charles St South

City Boston

State MA 02116

Account Representative:
Ricky Zeng

This design and engineering is submitted as our proposal, and the right to use or exhibit in any form, is not authorized without written permission by New CC Sign & Storefront.

Customer Sarah Lee

Phone 201-230-3756

Job No. 03688

Designer FL

Design # _____

Original Date 05/18/2022

Revision Date _____

All electrical scope to be completed in a U.L. approved method and shall meet current N.E.C. standards



- * All electrical components shall be U.L. Listed.
- * Sign shall be grounded per N.E.C. Article 250.
- * Insulated conductors as per N.E.C. Code 310.8. type to be used - metallic insulated sealite.
- * Disconnect switch as per N.E.C. Code 600.6.

NEW CC SIGN

sign & storefront

The purchaser agrees to hold the seller harmless against any cause for action for damages which may occur as a result of drilling for piers and foundations, including but not limited to sewer, gas lines or any underground obstacles which the purchaser or others may deem valuable.

SIGN
1
SIGN
2





CHARLES SIDENTAL

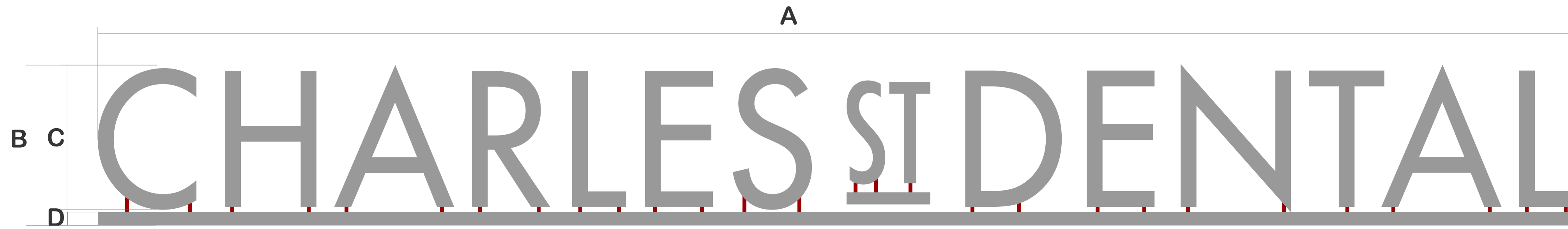

Address 121 Charles St South

City Boston

State MA 02116

Account Representative:
Ricky Zeng

This design and engineering is submitted as our proposal, and the right to use or exhibit in any form, is not authorized without written permission by New CC Sign & Storefront.

	A	B	C	D	SQUARE FEET
	138"	15"	13.88"	1.25"	14.38

Customer Sarah Lee

Phone 201-230-3756

Job No. 03688

Designer FL

Design # _____

Original Date 05/18/2022

Revision Date _____

All electrical scope to be completed in a U.L. approved method and shall meet current N.E.C. standards



- * All electrical components shall be U.L. Listed.
- * Sign shall be grounded per N.E.C. Article 250.
- * Insulated conductors as per N.E.C. Code 310.8. type to be used - metallic insulated sealite.
- * Disconnect switch as per N.E.C. Code 600.6.

SPECIFICATION SECTION DETAIL MOUNTING DETAILS

- 1** 3/4" PVC with aluminum face
- 2** 1.25"x1.25" Aluminum bar
- 3** Aluminum stud

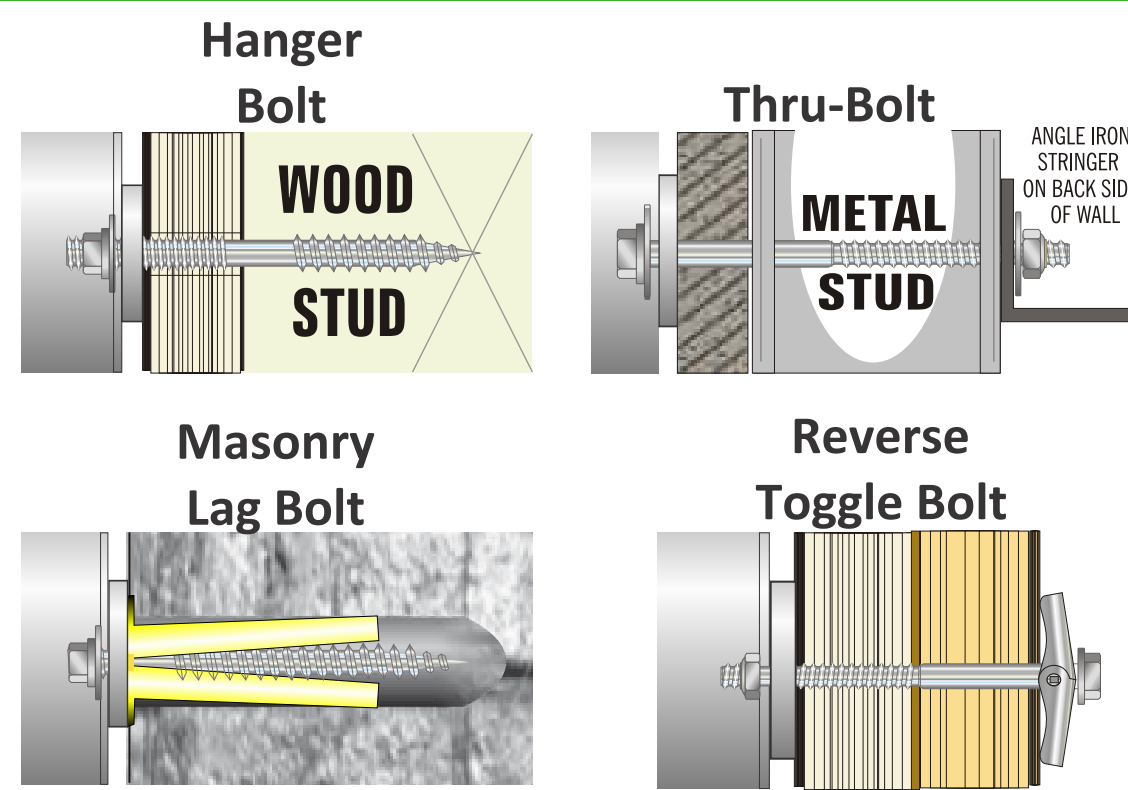
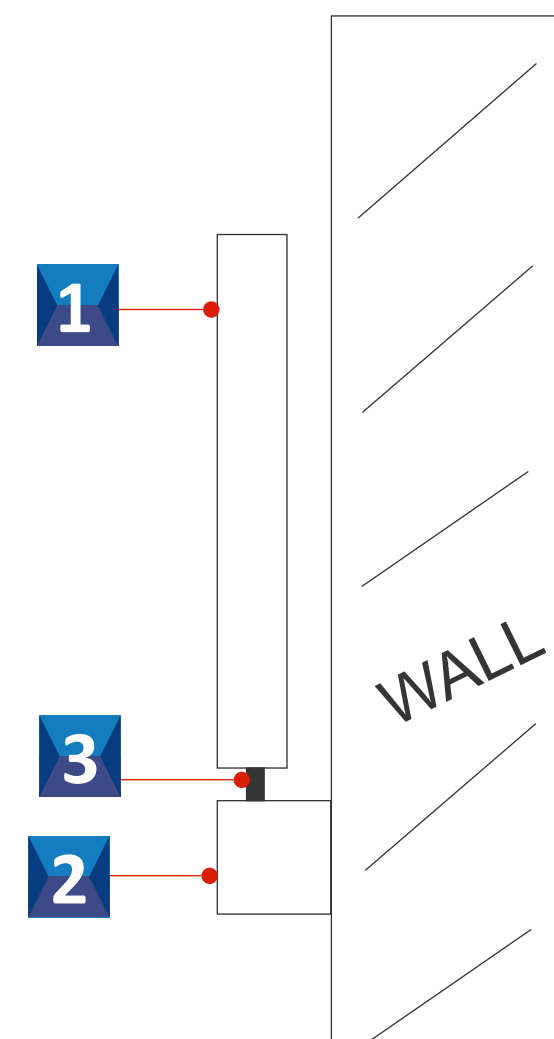

*All Hardware to be Galvanized and Non Corrosive

COLOR SCHEDULE

- Brush Satin Anodized Aluminum
- Burgundy Color

NEW CC SIGN

sign & storefront



The purchaser agrees to hold the seller harmless against any cause for action for damages which may occur as a result of drilling for piers and foundations, including but not limited to sewer, gas lines or any underground obstacles which the purchaser or others may deem valuable.

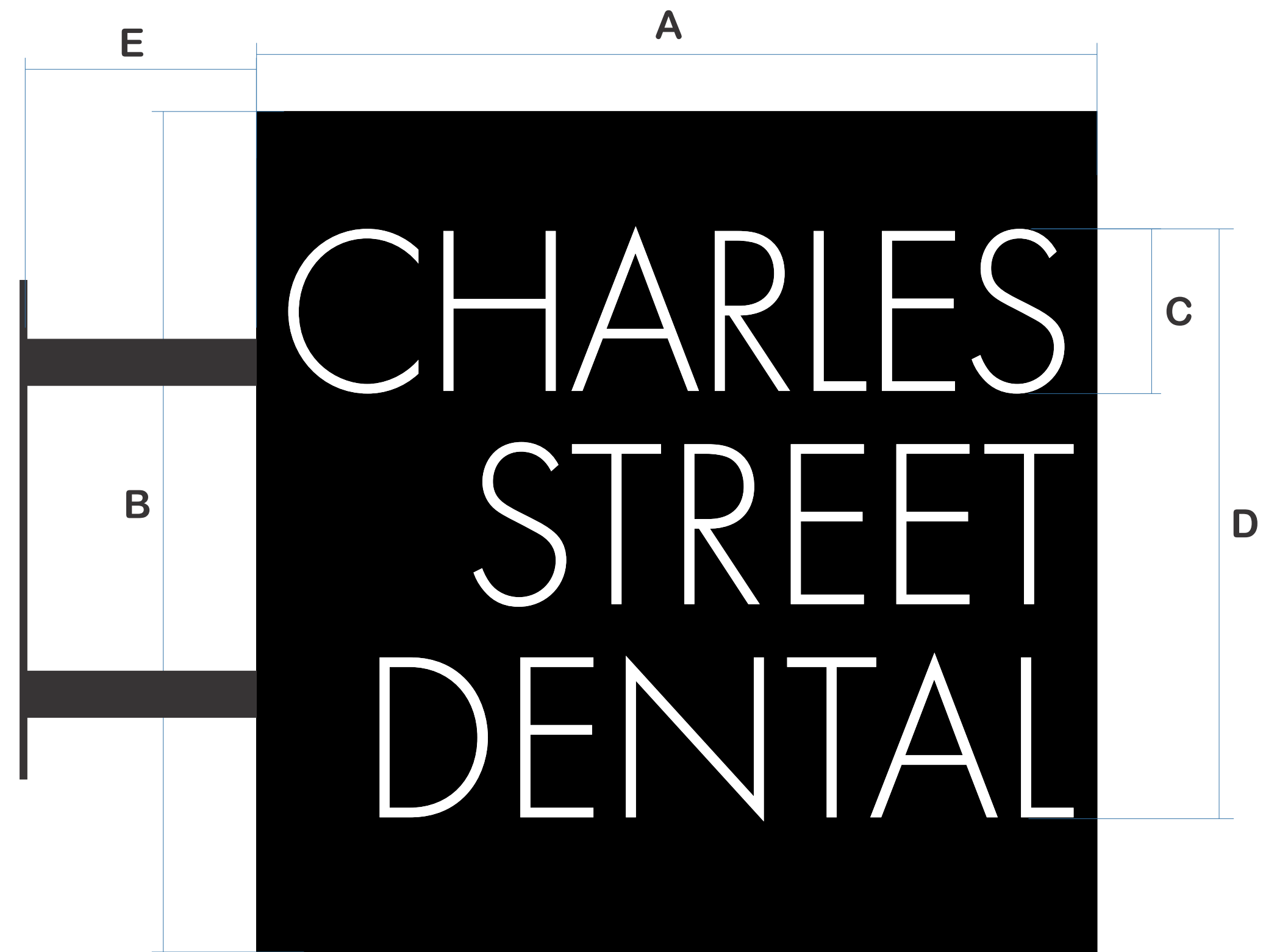

	A	B	C	D	E	SQUARE FEET
SIGN 1	18"	18"	3.58"	12.75"	5"	2.25

SPECIFICATION

- 1** 1" DEEP 040 ALUMINUM BOX w. 1"x1" GALVANIZED TUBING FRAME
- 2** 1/2" white pvc letter
- 3** 5"x12"x3/16" Steel plate

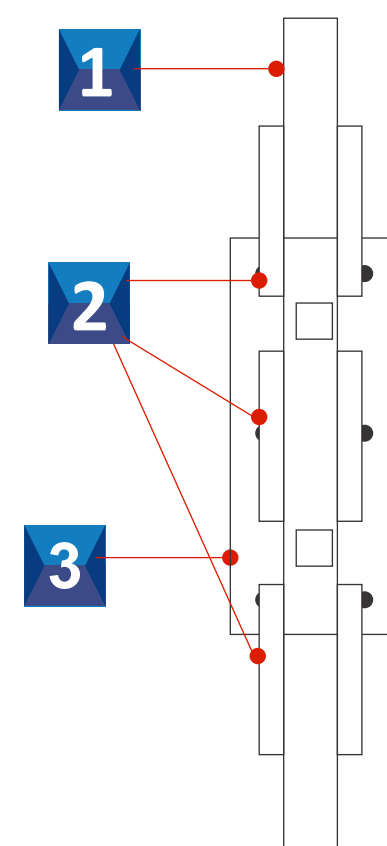

SIDE VIEW

MOUNTING DETAILS

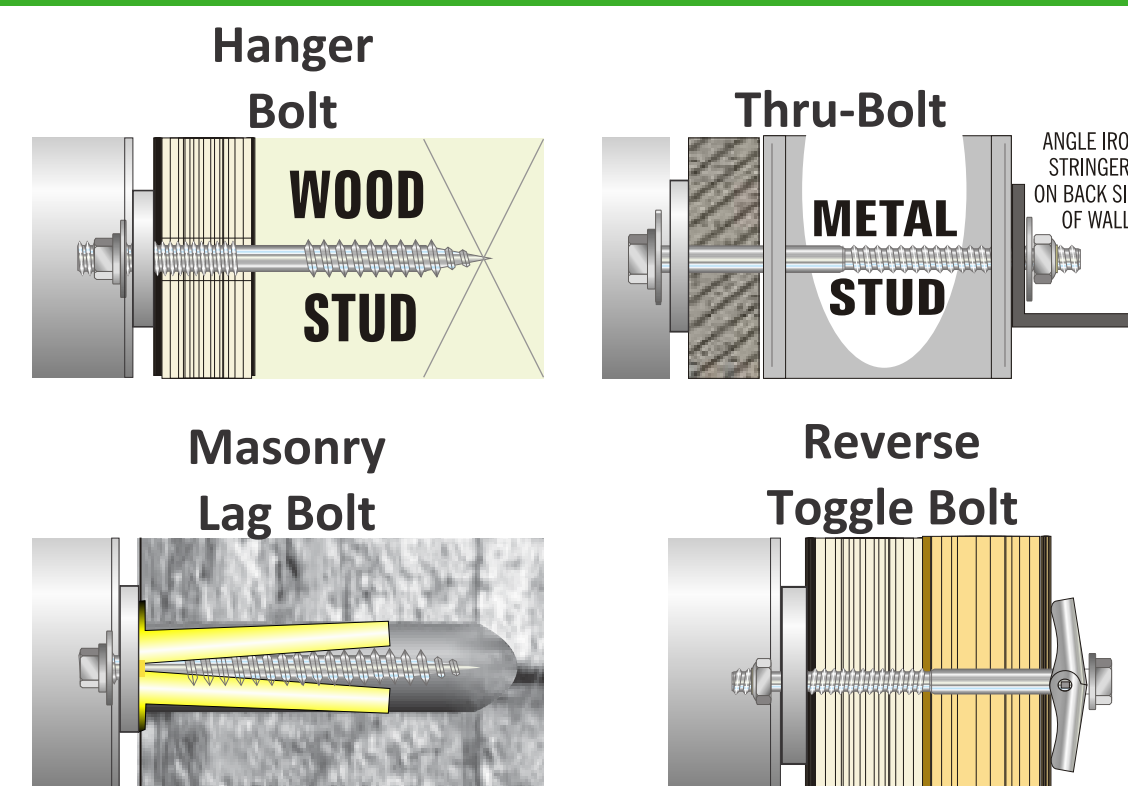

*All Hardware to be Galvanized and Non Corrosive



Black Aluminum

White PVC

CHARLES DENTAL

Address **121 Charles St South**

City **Boston**

State **MA 02116**

Account Representative:
Ricky Zeng

This design and engineering is submitted as our proposal, and the right to use or exhibit in any form, is not authorized without written permission by New CC Sign & Storefront.

Customer **Sarah Lee**

Phone **201-230-3756**

Job No. **03688**

Designer **FL**

Design #

Original Date **05/18/2022**

Revision Date

All electrical scope to be completed in a U.L. approved method and shall meet current N.E.C. standards



- * All electrical components shall be U.L. Listed.
- * Sign shall be grounded per N.E.C. Article 250.
- * Insulated conductors as per N.E.C. Code 310.8. type to be used - metallic insulated sealrite.
- * Disconnect switch as per N.E.C. Code 600.6.

NEW CC SIGN

sign & storefront

The purchaser agrees to hold the seller harmless against any cause for action for damages which may occur as a result of drilling for piers and foundations, including but not limited to sewer, gas lines or any underground obstacles which the purchaser or others may deem valuable.

Existing



CHARLES STREET DENTAL

Proposed



CHARLES STREET DENTAL

Address **121 Charles St South**

City **Boston**

State **MA 02116**

Account Representative:
Ricky Zeng

This design and engineering is submitted as our proposal, and the right to use or exhibit in any form, is not authorized without written permission by New CC Sign & Storefront.

Customer **Sarah Lee**

Phone **201-230-3756**

Job No. **03688**

Designer **FL**

Design #

Original Date **05/18/2022**

Revision Date

All electrical scope to be completed in a U.L. approved method and shall meet current N.E.C. standards



- * All electrical components shall be U.L. Listed.
- * Sign shall be grounded per N.E.C. Article 250.
- * Insulated conductors as per N.E.C. Code 310.8.
- type to be used - metallic insulated sealite.
- * Disconnect switch as per N.E.C. Code 600.6.

NEW CC SIGN

sign & storefront

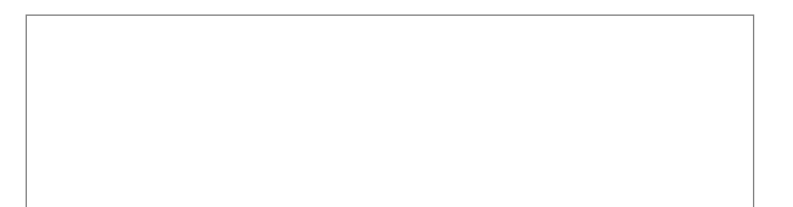

The purchaser agrees to hold the seller harmless against any cause for action for damages which may occur as a result of drilling for piers and foundations, including but not limited to sewer, gas lines or any underground obstacles which the purchaser or others may deem valuable.