



-  Roof deck
-  HVAC, Existing location
-  HVAC, New location



CITY OF BOSTON

THE ENVIRONMENT DEPARTMENT

Boston City Hall, Room 805 • Boston, MA 02201 • 617/635-3850 • FAX: 617/635-3435

12 February 2010

SOUTH END LANDMARK DISTRICT COMMISSION

Stephen Danner
14 Silver Birch Avenue
Plymouth, MA 02360

CERTIFICATE OF DESIGN APPROVAL

NOTICE OF DECISION

Application #10.855 SE
164 West Newton Street, Unit #2

Dear Mr. Danner:

At its January 5, 2010 public hearing, the South End Landmark District Commission (SELDC) reviewed your application to perform work on the roof of 164 West Newton Street. This work involves installing a roof deck, relocating the roof hatch and installing a new skylight on the rear portion of the roof. Other work, proposed for the rear elevation of the building and exempt from review by the SELDC, involves installing a balcony and French doors at the top story and blocking one window at this location. The Commission anticipated that the proposed roof deck at 164 West Newton Street would likely be visible from locations along West Newton Street, where the open space of Hiscock Park is located.

As noted in the South End Landmark District Standards and Criteria, roof decks, including decking and railing, should not be visible from any public way. Partial visibility of the railing may be allowed on a case-by-case basis based on criteria listed in the Standards and Criteria. Any visible railings must be black metal.

The Commission voted to remand decision on your application to a Subcommittee, consisting of Commissioners Gamp and Sanborn. The Subcommittee met with you on January 11, 2010 for the purpose of observing a mockup of the roof deck railing at different setback distances from the roof edge at the rear of building. The mock up showed that the roof deck as proposed, set back 7 feet 7 inches from the roof edge overlooking Hiscock Park, would be highly visible across the open space of Hiscock Park from points along West Newton Street and from the intersection of West Newton Street and Columbus Avenue.

During the observation of the roof at 164 West Newton Street as it appears across Hiscock Park, the Commissioners considered the nearby roof deck at 170 West Newton Street, which is located north of the park and alley. Commission files show that a roof deck had been approved at 170 West Newton Street in 1990.

The Subcommittee approved the proposed roof deck at 164 West Newton Street, with the following provisos:

1. The set back of the roof deck and its railing shall be increased to 11 feet 7 inches from the roof edge overlooking Hiscock Park, in order to reduce its visibility.
2. As an alternative to a 36 inch high black metal railing, the Subcommittee suggests that the applicant consider the use of planters combined with a low railing (no more than 18 inches high) on the side of the deck that is closest to Hiscock Park. It is up to the applicant to determine if this suggested alternative will meet building code.

These determinations are based solely upon the information submitted to the staff with the application and presented before the Commission. If statutory reviews by other authorities conflict with this decision, those actions may affect the status of this certificate. This certificate is valid for two years from the date of issue. The applicant is required to notify the Commission of any changes to this proposal, and failure to do so may affect the status of this

D. Bryan Glascock, Director



Thomas M. Menino, Mayor

certificate. The Commission reserves the right to require remedial action to bring work into compliance with Commission standards if any work occurring without a Certificate of Design Approval results in significant change in the appearance of the building or if work does not meet the noted specifications of a Certificate of Design Approval.

Please bring a copy of this certificate with you when filing for permits from the Inspectional Services Department (1010 Massachusetts Avenue). Photographs of the completed project should be submitted to the Commission office to confirm compliance with the terms of this certificate.

If you have any questions about this certificate, do not hesitate to contact me at 617-635-3850.

Sincerely,

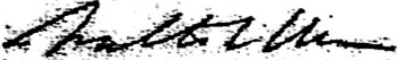

Wallace Maros
Preservation Planner
South End Landmark District Commission

Vote on Application #10.855 SE to Remand Approval to Subcommittee

Motion by FREEMAN Second by AMODEO

AFFIRMATIVE: Amoden, Freeman, Hunt, Gamp, Sanborn NEGATIVE: (None)

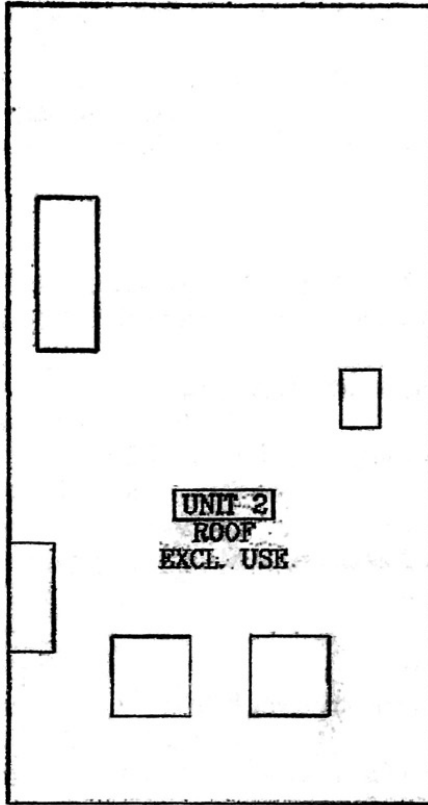

ROOF

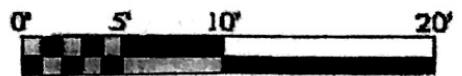

**164 WEST NEW STREET
CONDOMINIUM
BOSTON, MASSACHUSETTS 02118**

UNIT 2 1581 SQUARE FEET

**JONATHAN RAISZ
ARCHITECT**

**PHONE (617) 734-1040
RAISZ@RCN.COM**



Existing Conditions



Photo of 170 West Newton
As viewed directly next door
from 164 West Newton sidewalk

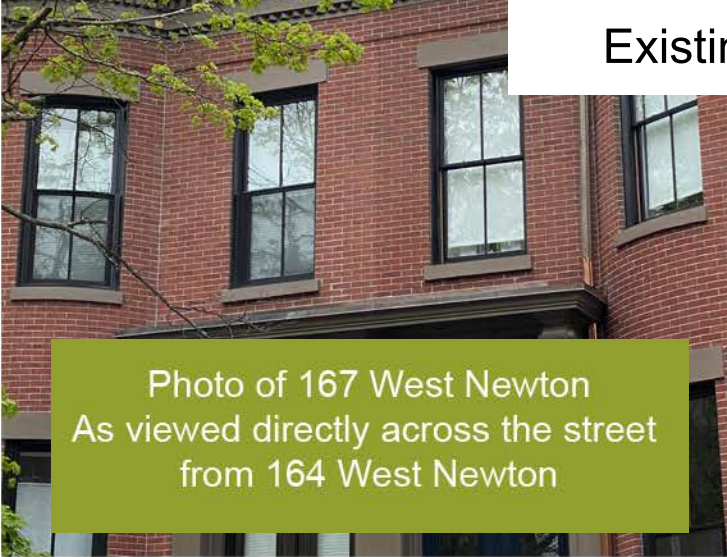
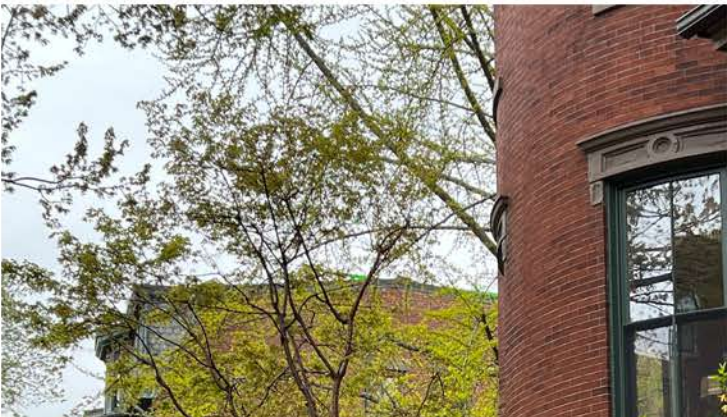

Photo of 167 West Newton
As viewed directly across the street
from 164 West Newton



Proposed Conditions



Photo of 164 West Newton
As viewed down street,
same side, at 170/172 West Newton

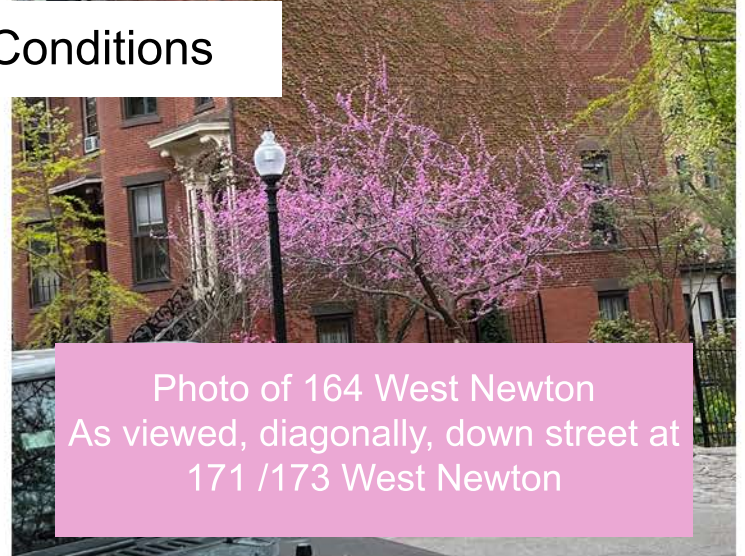
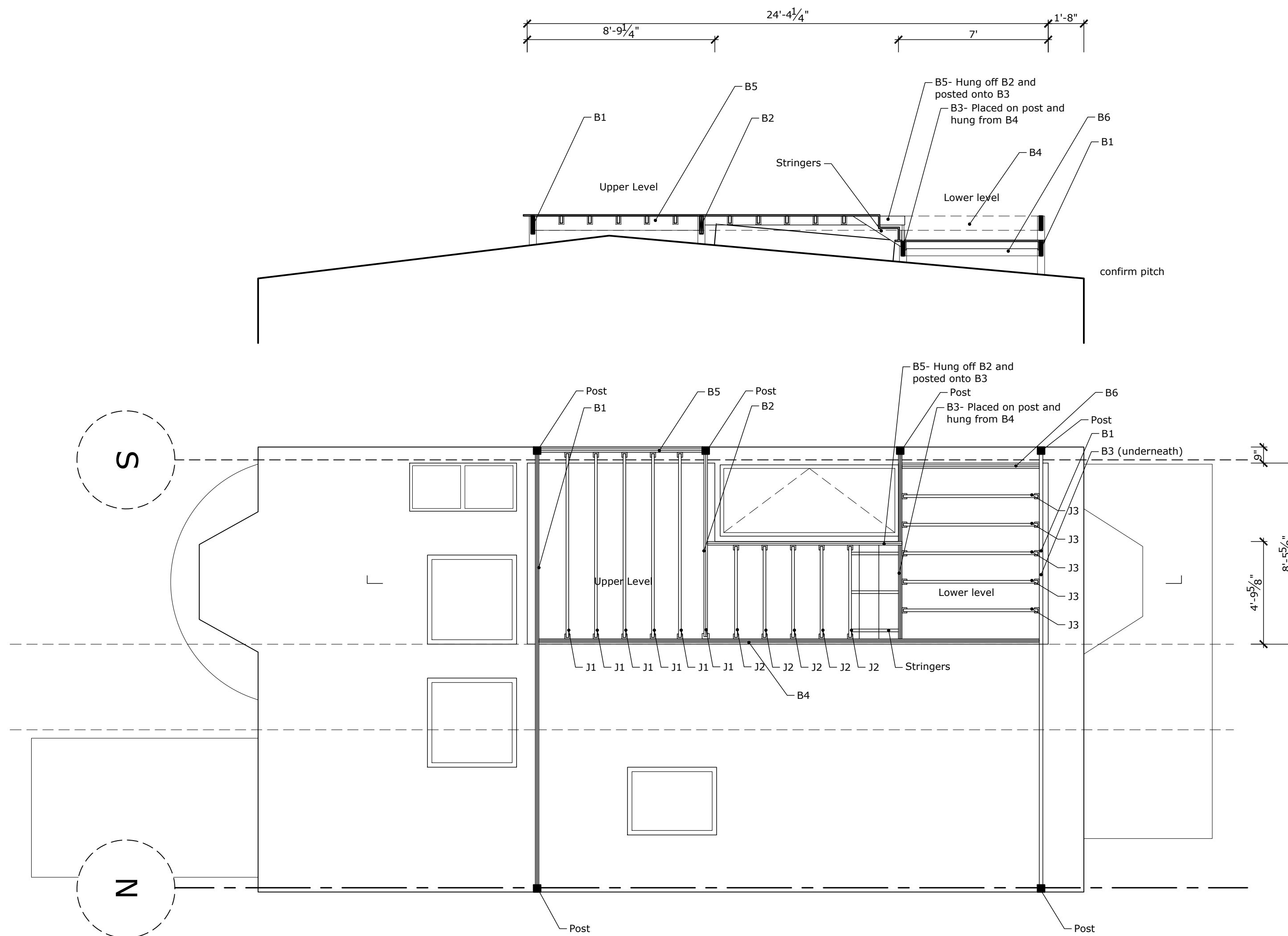

Photo of 164 West Newton
As viewed, diagonally, down street at
171 /173 West Newton

ALL INFORMATION PROVIDED BY RP&I, INCLUDING: LAYOUT DESIGN, DOCUMENTS, DETAIL DESIGN & DEVELOPMENT, ENGINEERING, CONCEPTS, MODELS, ELECTRONIC FILES, IS CONFIDENTIAL AND SHALL REMAIN THE PROPERTY OF RP&I. ALL INFORMATION PROVIDED BY RP&I TO THE DESIGN TEAM, OWNERS, CONSTRUCTION MANAGERS, OR ANY OTHER PARTY SHALL BE UTILIZED ONLY FOR THE PURPOSES OF DESIGN, COORDINATION, AND CONSTRUCTION OF THE PROJECT IN CONJUNCTION WITH RP&I. CONFIDENTIAL INFORMATION SHALL BE KEPT STRICTLY CONFIDENTIAL AND SHALL NOT BE SHARED OR DISBURSED TO ANY PARTIES OR INDIVIDUALS NOT DIRECTLY EMPLOYED BY THE PROJECT DESIGN AND OWNERSHIP TEAMS; THE INFORMATION SHALL NOT BE DISCLOSED TO ANY THIRD PARTY WITHOUT PRIOR WRITTEN APPROVAL.

#	Description	Date
00	CONCEPTUAL 1	02.10.22



1 Deck Structure
1/4" = 1'-0"

PROJECT:
GOULD

ADDRESS:
164 W. Newton St.
Boston, MA 02118

JOB NUMBER: 21-1004

TITLE:
Deck Structure Elevations

DRAFTED BY: IK
CHECKED BY:
DATE: 03.08.2022

DRAWING NO:
A-201

GENERAL

- These drawings represent the completed project which has been designed for the weights of materials, for the superimposed loads indicated in the design load criteria above, and for loads indicated on the drawings. It is the Contractor's responsibility to determine allowable construction loads and to provide proper design and construction of false work, staging, bracing, sequencing, sheeting and shoring, etc.
- Carefully check stability of all elements of the building before doing any work on existing structures. Brace or strengthen all portions of structure which may be weakened by removal of existing construction until new construction is in place. For any temporary bracing, shoring, and strengthening, submit design and supporting calculations sealed by a Professional Engineer for review.
- Developing and implementing job site safety and construction procedures are solely the responsibility of the Contractor. These responsibilities include but are not limited to the safety of adjacent structures, property, their workers, and the public, as affected by the construction of this project.
- Bring any discrepancies between Structural Drawings and Architectural Drawings, if not clarified in the addenda, to the attention of the Architect/Engineer during construction for clarifications.
- Do not scale drawings to obtain any missing information or to interpret any information not specifically dimensioned for exact detailing or construction purposes.
- Repair any deficient work and/or work not in conformance with the contract documents at the contractor's expense. Compensate the client for services arising from deficient work, review of modifications/contractor substitution, or expediting of submittals.
- See Architectural Drawings and Specifications for detailed information regarding finishes, waterproofing, fireproofing, etc.
- In case of conflict between the general notes and details, the most stringent shall govern.
- Work in some areas is not explicitly detailed on the drawings but is implied to be similar to corresponding areas. Work in these areas shall be the same as that shown at the corresponding locations.

SPECIFICATIONS

- The work shown on these drawings addresses structural information only. The structural documents include these S-series Drawings and General Notes. There are no technical specifications in addition to these General Notes.

ELEVATIONS AND DIMENSIONS

- All elevations and dimensions shown for new construction are based on the Architectural Drawings. Coordinate all elevations and dimensions before proceeding with construction.
- Existing building information shown is based on field observations and as indicated on the architectural drawings. Verify all existing building information shown (dimensions, elevations, etc.) and notify the Architect and Structural Engineer of any discrepancies.

BUILDING CODE

- The following building codes and standards, including all specifications referenced within, shall apply to the design, construction, quality control, and safety of all work performed on the project.
 - "Minimum Design Loads for Buildings and Other Structures," (ANSI/ASCE 7 – 10, 2010), American Society of Civil Engineers.
 - Additional codes and standards for different materials are listed in the sections that follow.

DESIGN LOADS

- Superimposed Dead Loads:

A. Decking	5 psf
------------	-------
- Dead Loads:

A. Steel Self-Weight	10 psf
B. Joist Self Weight	10 psf
- Uniform Live Loads

A. Deck area	100 psf
--------------	---------
- Show Load – Plus Drifting and Sliding Where Applicable

A. Ground Snow Load, P _g	40 psf
B. Flat Roof Snow Load, P _f	30 psf
C. Snow Exposure Factor, C _e	0.9
D. Snow Load Importance Factor, I _s	1.0
E. Thermal Factor, C _t	1.2
- Wind Load Parameters

A. Basic Wind Speed (3-Second Gust), V	128 MPH
B. Wind Importance Factor, I _w	1.0
C. Wind Exposure Category	C
D. Internal Pressure Coefficient	+/- 0.18

Existing Buildings: The scope of work on this project does not change the demand upon nor reduce the resistance provided by the wind force resisting systems (WFRS) by more than 10%. Based on IEBC requirements, no evaluation or upgrade of the existing WFRS has been conducted.
- Components and Cladding
 - Actual pressure(s) on every component and cladding element shall be determined by the contractor's specialty professional engineer, licensed in the project's jurisdiction, who is responsible for the structural design of such element(s). Pressure values listed below are for reference only and based on an effective area of 10 sf.

*+ indicates inward pressure; *- indicates outward pressure.

REFERENCE PRESSURES FOR ROOFS:

a. ZONE 1:	+18 PSF;	-45 PSF
b. ZONE 2:	+18 PSF;	-75 PSF
c. ZONE 3:	+18 PSF;	-111 PSF
- Beam Deflection Criteria

A. Non-Composite Steel Beams	
1. Live Load Deflection	span/360
2. Net Total Deflection, Typical Conditions	lesser of span/240 or 1 in.

STRUCTURAL STEEL & MISC. METALS

- CODES AND STANDARDS:
 - "The Specification for Structural Steel Buildings," AISC 360-10, American Institute of Steel Construction, Inc.
 - "Code of Standard Practice for Steel Buildings and Bridges," AISC 303-10, American Institute of Steel Construction.
 - "Structural Welding Code – Steel," AWS D1.1-2010, American Welding Society.
- DESIGN GUIDES:
 - "Steel Construction Manual," Fourteenth Edition, American Institute of Steel Construction, Inc., 2010.
- STRUCTURAL SHAPES:

A. WIDE FLANGE SHAPES:	ASTM A992
B. ANGLES, PLATES, AND CHANNELS:	ASTM A36
C. RECTANGULAR/SQUARE HSS:	ASTM A500, GRADE C OR ASTM A1085 GRADE A, FY = 50 KSI
- FASTENERS AND CONNECTORS:

A. HIGH STRENGTH BOLTS:	ASTM F3125 GRADE A325 OR F1852
Tension-control bolts acceptable.	
B. HIGH STRENGTH NUTS:	ASTM A563 HEAVY HEX CARBON-STEEL NUTS
C. HIGH STRENGTH WASHERS:	ASTM F436 HARDENED CARBON-STEEL WASHERS
D. WELDING ELECTRODES:	
1. Conform to AWS Specifications for electrodes based on welding process and the type and grade of steel.	
2. E70XX electrodes (min.) For fillet welds.	
3. Use 70 ksi low hydrogen electrodes for welding to existing construction.	
E. ADHESIVE FOR DOWELING INTO MASONRY:	AC108+ GOLD® Vinylster Injection Adhesive Anchoring System (ESR-4105)
- BASE PLATE GROUT:

ASTM C1107 NON-METALLIC, 8,000 PSI 28-DAY COMPRESSIVE STRENGTH.

- FABRICATION:
 - Shop fabricate to greatest extent possible by welding, including beam stiffeners, column caps and bases, holes, and connections. Submit complete shop drawings from field dimensions for the Architect's approval of all structural steel prior to fabrication.
 - Prior to starting fabrication, submit certified copies of the mill test reports to the Structural Engineer for review.
 - Connections shown on these drawings are generally schematic. They are intended to define the spatial relationship of the framed members and show a feasible method of making the connection. Any connection that is not shown or is not completely detailed on the structural drawings shall be designed by a registered Professional Engineer, retained by the fabricator.
 - Details and connections completely detailed in the Contract Drawings may not be altered without written approval by the EOR. Where approved, fabricator's engineer shall completely and clearly detail any altered connections on the shop drawings.
 - Cut, drill, or punch holes. Do not thermally cut bolt holes or enlarge by burning.
 - Min. 1/2" radius at all copes and re-entrant corners.
 - Provide 1/2" set back at all copes.
- ERECTION:
 - Tighten all bolts to a "snug-tight" condition, unless noted otherwise.
 - Provide anchor rods, steel wedges, threaded screws, or shims to support and plumb all columns. Grout solid under base plates immediately after columns are plumb.
 - Do not field cut or field modify any structural steel without prior written approval by the Structural Engineer for each specific case. True and plumb all structural steel framing before connections are finally bolted or welded.
 - Notify the Structural Engineer of any fabrication or erection errors or deviations and receive written approval before any field corrections are made. Do not use gas cutting torches to correct fabrication errors without the approval of the structural engineer.
 - Permanent framing and final connection details are shown on the drawings. The fabricator and erector are responsible for the design of temporary bracing and recommend erection procedures.
- CONNECTIONS:
 - Make all shop and field connections with high strength bolts or welds. All high strength bolts and nuts shall be clearly marked as required by AISC specification. Connections made with unmarked bolts and nuts will be rejected.
 - Provide access for inspection of all shop and field connections for proper material and workmanship.
 - Contractor Note: Alternate connector designs shall only be allowed with prior approval of the Structural Engineer. If such approval is granted, all connections, splices, and erection pieces not in accordance with the Contract Documents (fabricator's redesign) shall be designed by the Fabricator's Engineer registered in the project's jurisdiction. Submit calculations and shop drawings bearing the engineer's seal and signature.
 - Select connections for reactions as shown on plans and as detailed and scheduled. Connections shall consist of at least (2) 3/4 in. Diameter A325-N bolts or welds developing a minimum of 10,000 pounds (factored). Minimum fillet weld size is 3/16 in.
 - Unless detailed otherwise, tighten all A325 bolts to the 'snug tight' condition defined as the tightness attained by a few impacts of an impact wrench or the full effort of an ironworker using an ordinary spud wrench. The snug tight condition must ensure that the plies of the connected materials have been brought into snug contact.
 - When installing post-installed fasteners (adhesive anchors, expansion anchors, etc.), take measures to avoid drilling or cutting of any existing reinforcing steel and destruction of concrete (and masonry). Install all fasteners per the manufacturer's specifications [and relevant ICC-ES ESR].
 - Welding electrodes, welding process, minimum preheat, and interpass temperatures shall be in accordance with the AISC and AWS Specifications. Any structural damage in welding is to be replaced or reinforced as acceptable to the structural engineer.
 - Welders shall have current evidence of passing the appropriate AWS qualification tests. The engineer may request such evidence at any time during the project.
 - Where these drawings required welding new structural steel elements to existing structural steel elements, the Contractor is advised that the existing structural steel is under load, and welding must be performed in a controlled manner to prevent failure of the existing structural steel. Welds to the existing members should be produced to minimize the amount of the existing member that is heated at any one time. Complete welds in 2 in. max weld segments. Each weld segment should be allowed to cool to the touch prior to welding the next segment.
- STEEL FINISH:
 - Surface Preparation
 - Ensure surfaces to be coated are clean, dry, smooth, and free from dust and foreign matter which will adversely affect adhesion or appearance. Wipe with manufacturer's approved solvent as necessary to remove grease and debris.
 - Remove slag metal and splatters from all welds by chipping and grinding.
 - Hot-Dip Galvanizing: ASTM A123 / A153
 - All steel, including, but not limited to structural members, connection materials and misc. metals, that is exposed to the exterior elements.
 - Prepare steel in accordance with SSPC-SP6, "Commercial Blast Cleaning."
 - Touch up all field welds, or areas where hot-dip galvanizing is damaged, with a zinc-rich paint ("cold galvanizing") per ASTM A780 after steel is completely installed.
 - Plug weld vent holes and grind smooth after galvanizing.
 - Seal weld all seams not otherwise welded.
 - Tap all nuts and threaded components after galvanizing to minimum diametric amounts.
- INSPECTION AND TESTING:
 - The Owner shall engage a testing agency to provide services as indicated below and submit reports.
 - Structural Steel:
 - Visually inspect all welds, bolted connections, post-installed fasteners, and steel studs.
 - Post-installed adhesive anchors:
 - Inspect initial installations and then periodically throughout project.
 - Minimum inspection shall include:
 - Installer certification where required (vertical/overhead)
 - Hole drilling method and location, diameter, spacing, and depth of holes
 - Hole cleaning
 - Adhesive identification and expiration
 - Adhesive and anchor installation
 - The agency shall monitor the installation of bolts requiring pre-tensioning for conformance with specific pre-calibrated tightening procedures.
 - Test each complete joint penetration weld by the ultrasonic method (ASTM E164).
 - Test all multi-pass welds in primary connections by the magnetic particle method (ASTM E1444).
 - Test any weld which exhibits unusual conditions or poor quality during visual examination.
 - Welding inspection and testing procedures shall be in accordance with the AWS D1.1.

ABBREVIATION	WORD OR PHRASE
CONN	Connection
(E)	Existing
EMBED	Embedment
GALV	Galvanized
MIN	Minimum
TYP	Typical
UON	Unless Otherwise Noted
VIF	Verify in Field



SIMPSON GUMPERTZ & HEGER
 480 Totten Pond Road
 Waltham, MA 02451
 781.907.9000
sgh.com

Consultant

No.	Date	Description	By

GOULD RESIDENCE
 164 West Newton Street
 Boston, MA 02118

Project

Project No.

GENERAL NOTES

Drawing Title

Project No. 220288.00	Checked MAT	Date 04/19/22
Drawn MRM	Approved PJS	Scale 12" = 1'-0"

Drawing No.
S-001

Seal



SIMPSON GUMPERTZ & HEGER
480 Totten Pond Road
Waltham, MA 02451
781.907.9000
sgh.com

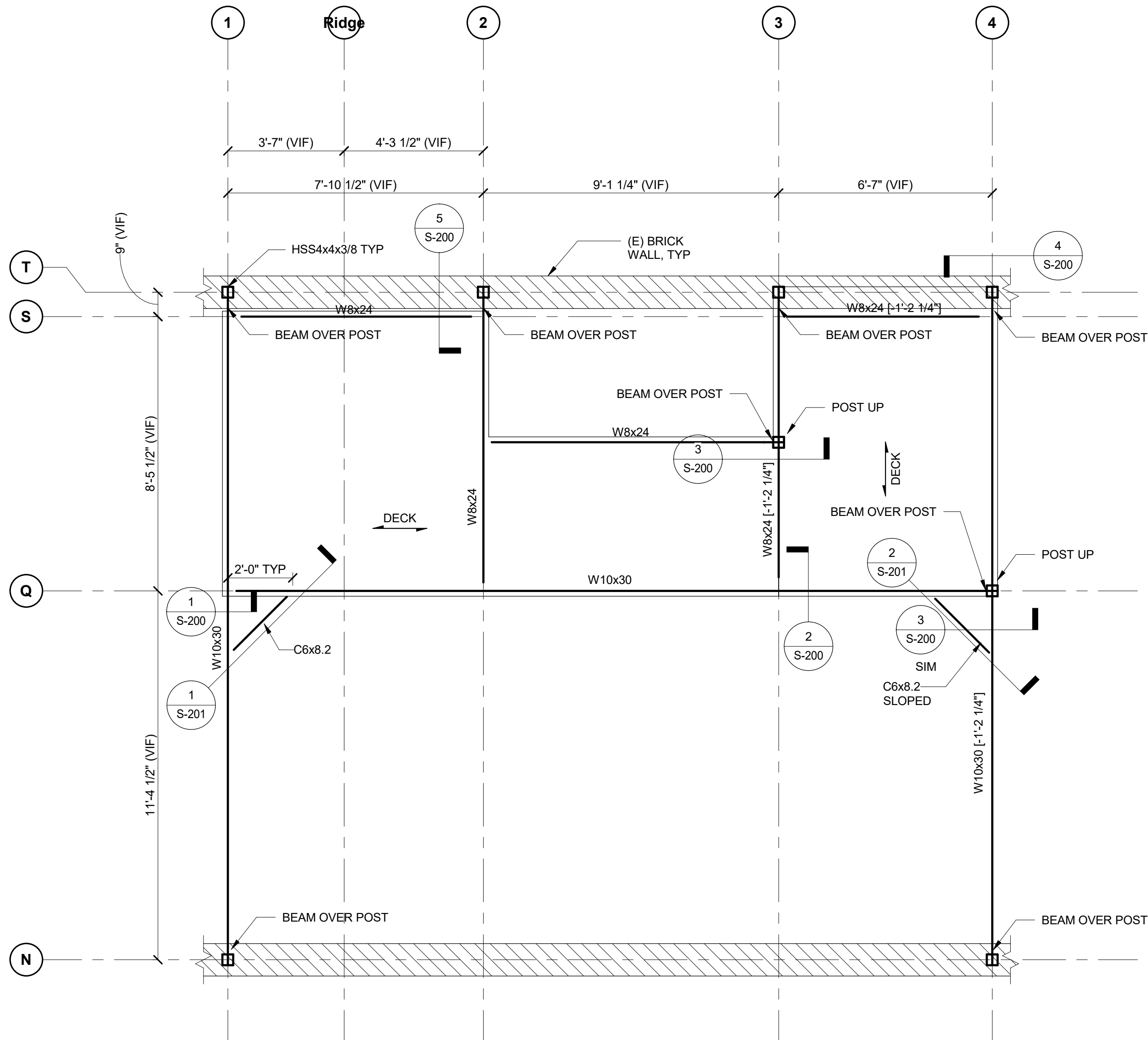

PLAN NOTES:

1. TYPICAL LEVEL TOP OF STEEL (TOS) IS ASSUMED TO BE 40' 0" ABOVE GRADE (V.I.F.).
2. [x'-x"] INDICATES OFFSET TOS FROM TYPICAL LEVEL TOS.
3. HOT DIP GALVANIZE ALL STEEL AND CONNECTORS, UON.

Consultant

No.	Date	Description	By

GOULD RESIDENCE
164 West Newton Street
Boston, MA 02118

Project

Project No.
**ROOF FRAMING
PLAN**

Drawing Title

Project No. 220288.00	Checked MAT	Date 04/19/22
Drawn MRM	Approved PJS	Scale 3/8" = 1'-0"

Drawing No.

S-101

Seal



SIMPSON GUMPERTZ & HEGER
 480 Totten Pond Road
 Waltham, MA 02451
 781.907.9000
 sgh.com

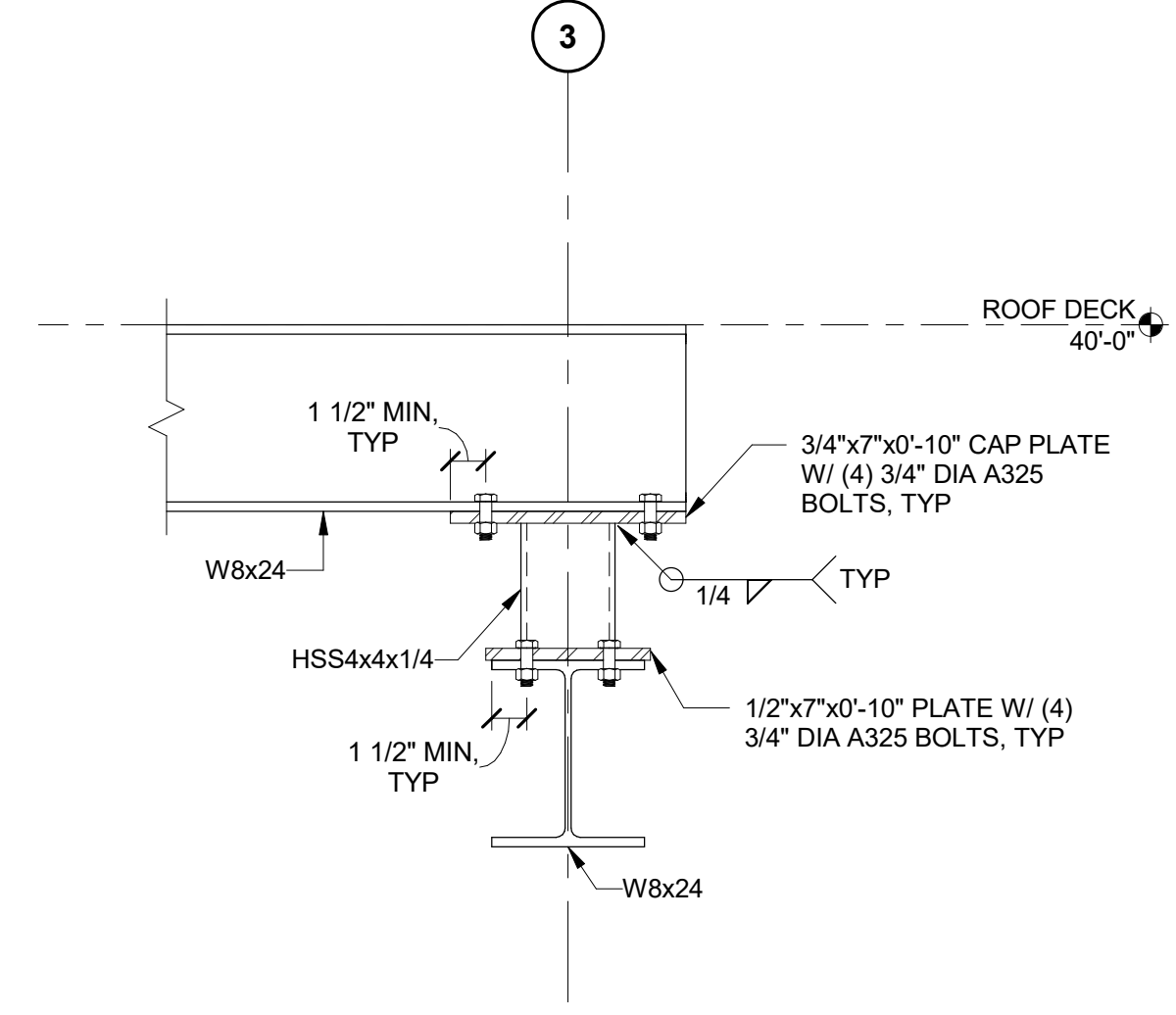
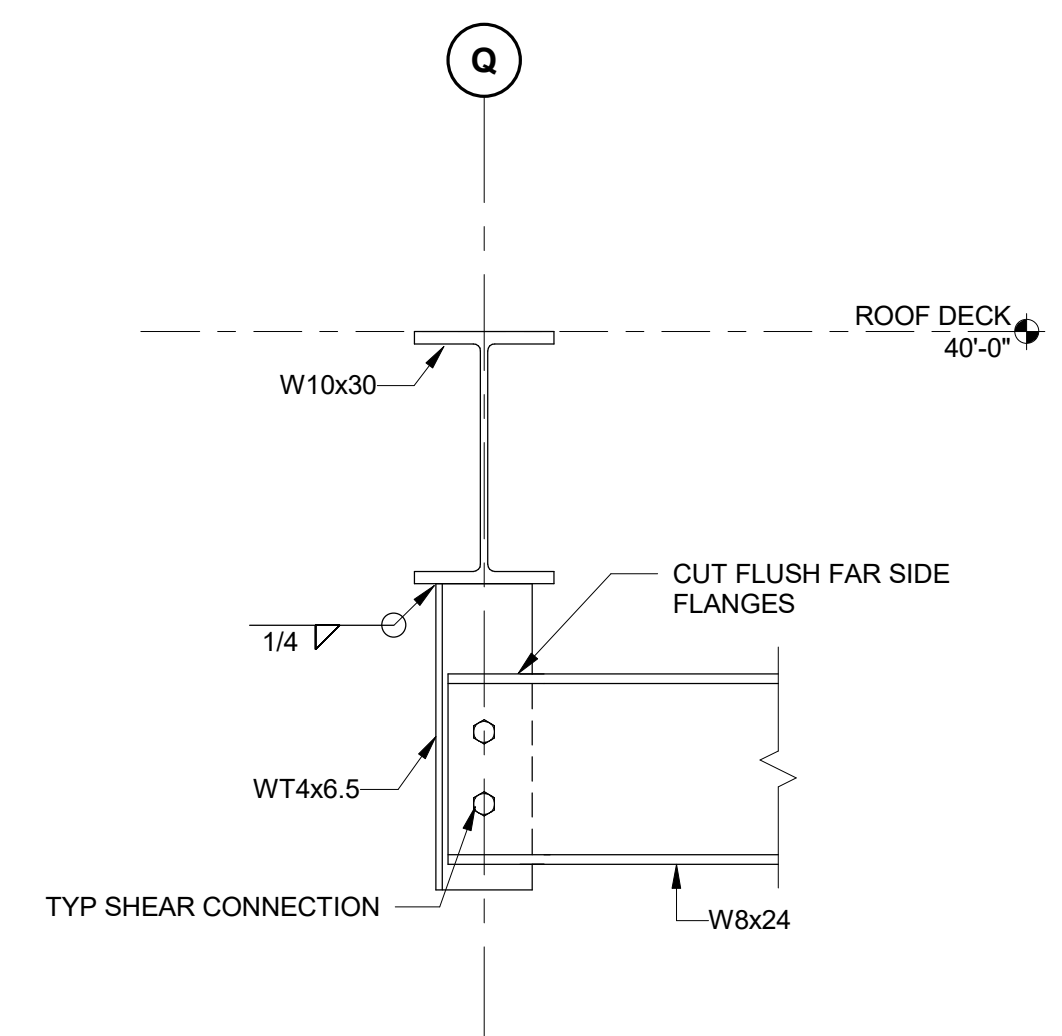
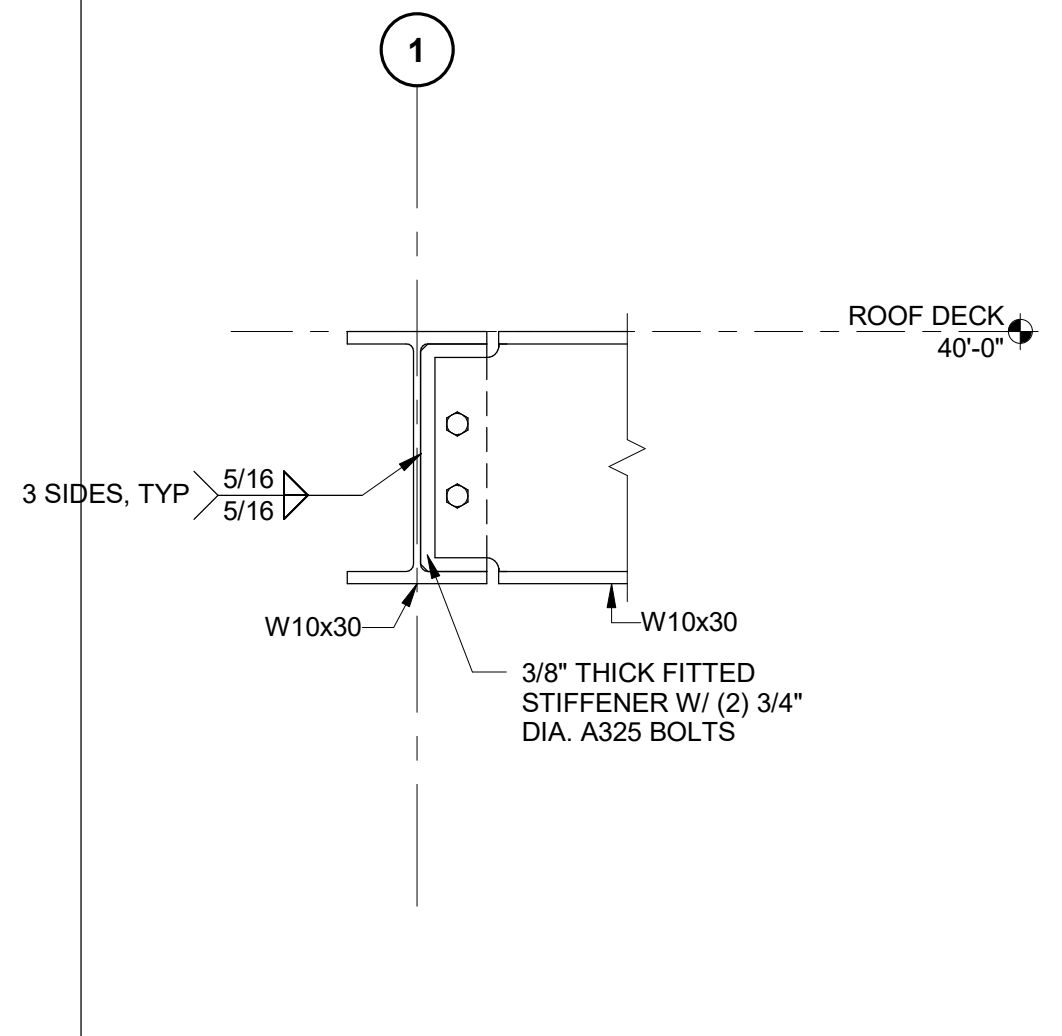

NOTES:
 1. DETAIL APPLIES AT W10-TO-W10 AND W8-TO-W8 BEAM CONNECTIONS

1 TYP. SHEAR CONNECTION
 1 1/2" = 1'-0"

2 HUNG FRAMING
 1 1/2" = 1'-0"

3 HIGH TO LOW DECK
 1 1/2" = 1'-0"

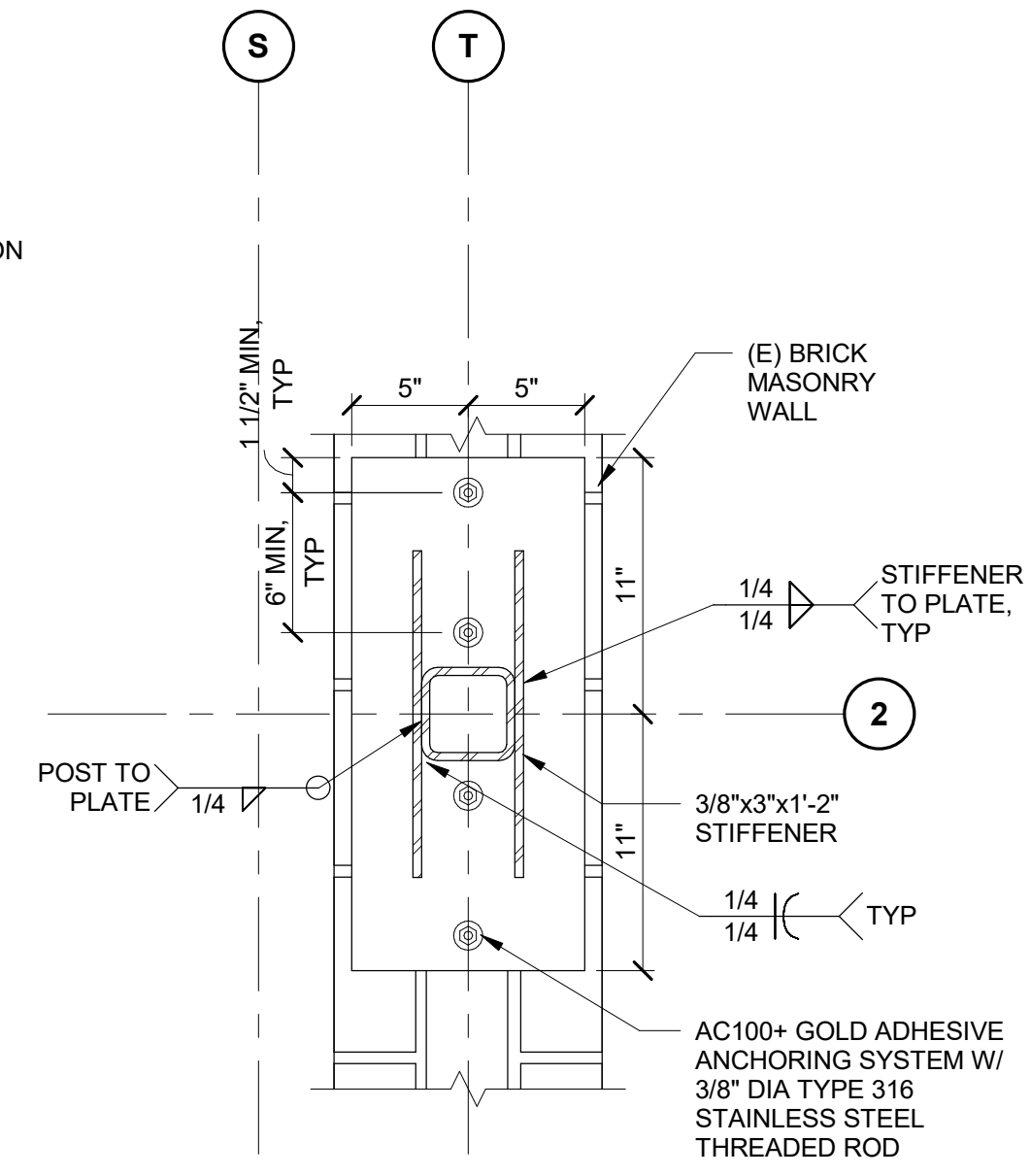
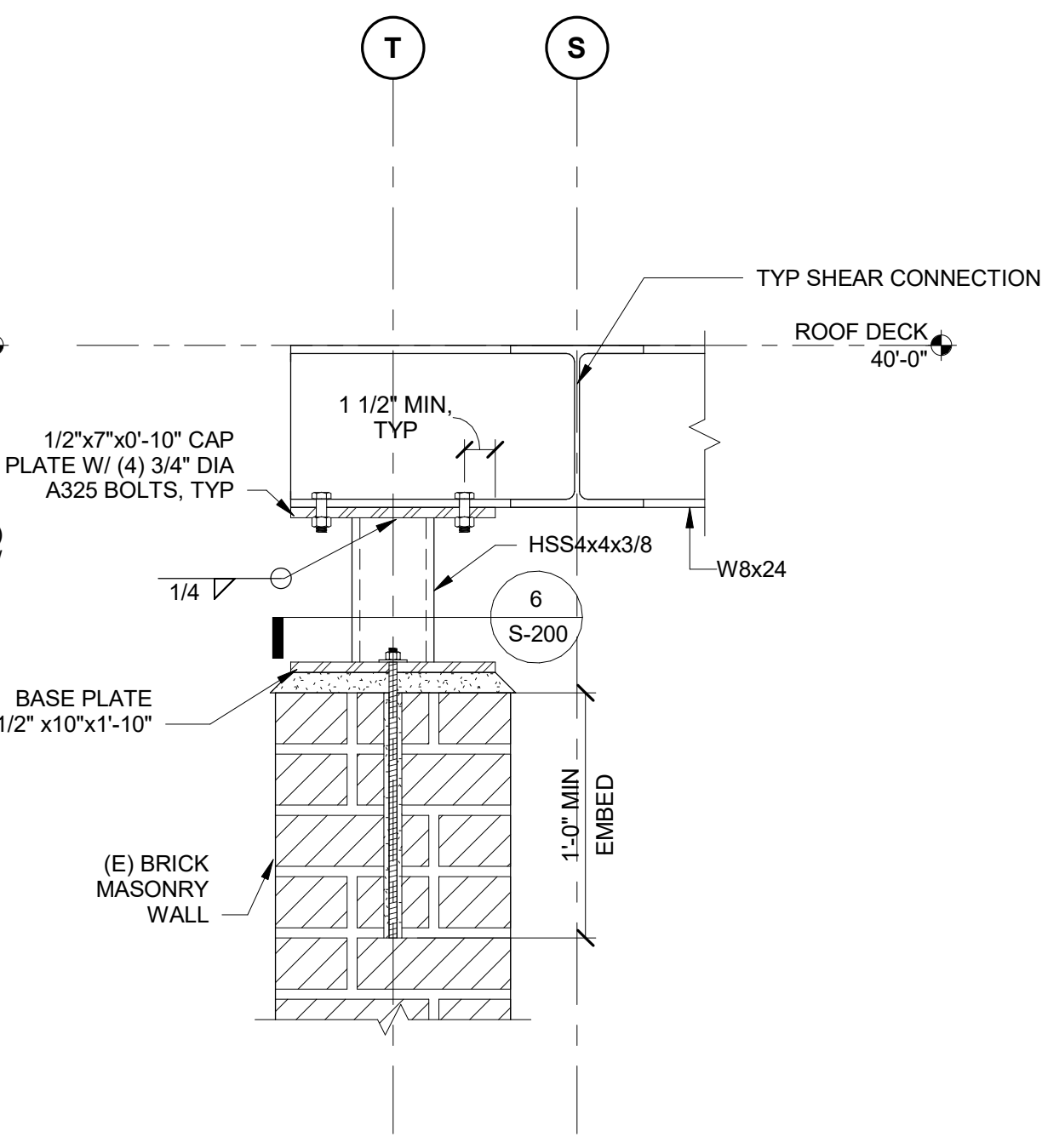
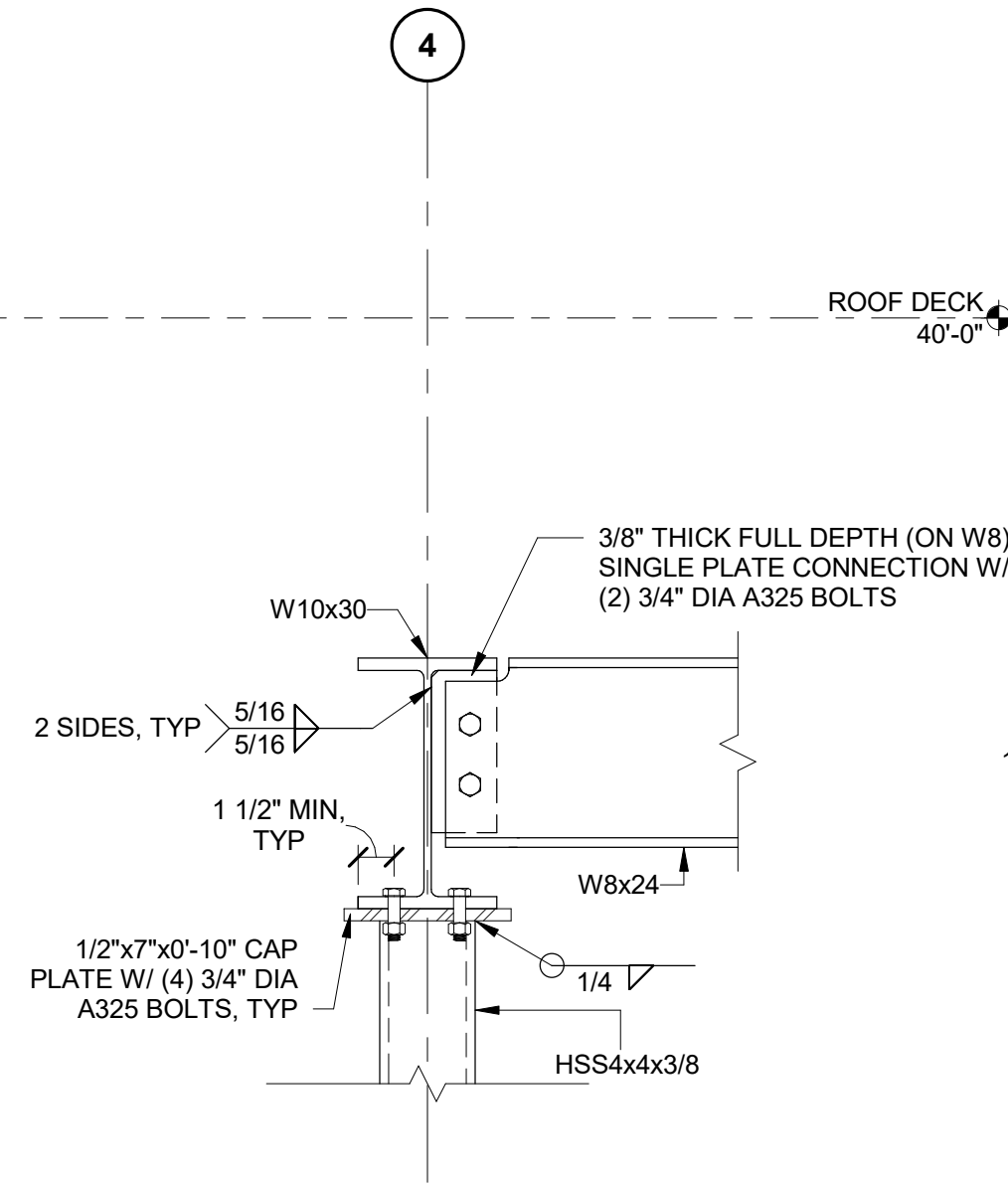

4 LOW FRAMING TO POST
 1 1/2" = 1'-0"

5 POST TO (E) WALL
 1 1/2" = 1'-0"

6 BASE PLATE DETAIL
 1 1/2" = 1'-0"

No.	Date	Description	By

GOULD RESIDENCE
 164 West Newton Street
 Boston, MA 02118

Project No.
SECTIONS AND DETAILS

Project No. 220288.00	Checked MAT	Date 04/19/22
Drawn MRM	Approved PJS	Scale 1 1/2" = 1'-0"

Drawing No.
S-200



SIMPSON GUMPERTZ & HEGER
 480 Totten Pond Road
 Waltham, MA 02451
 781.907.9000
sgh.com

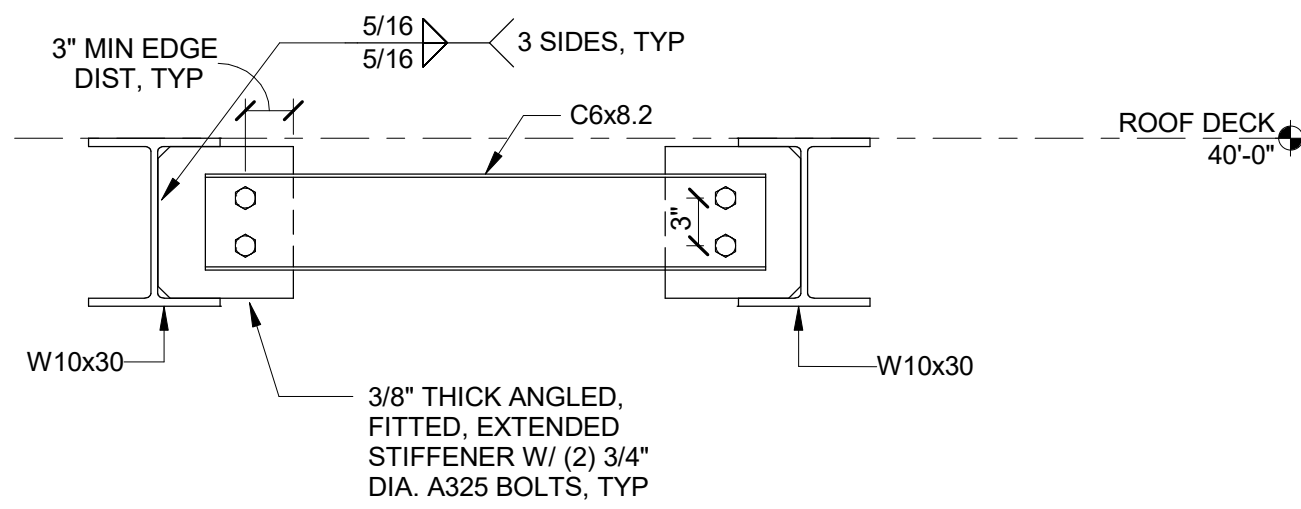

1 HORIZONTAL BRACE
 1" = 1'-0"

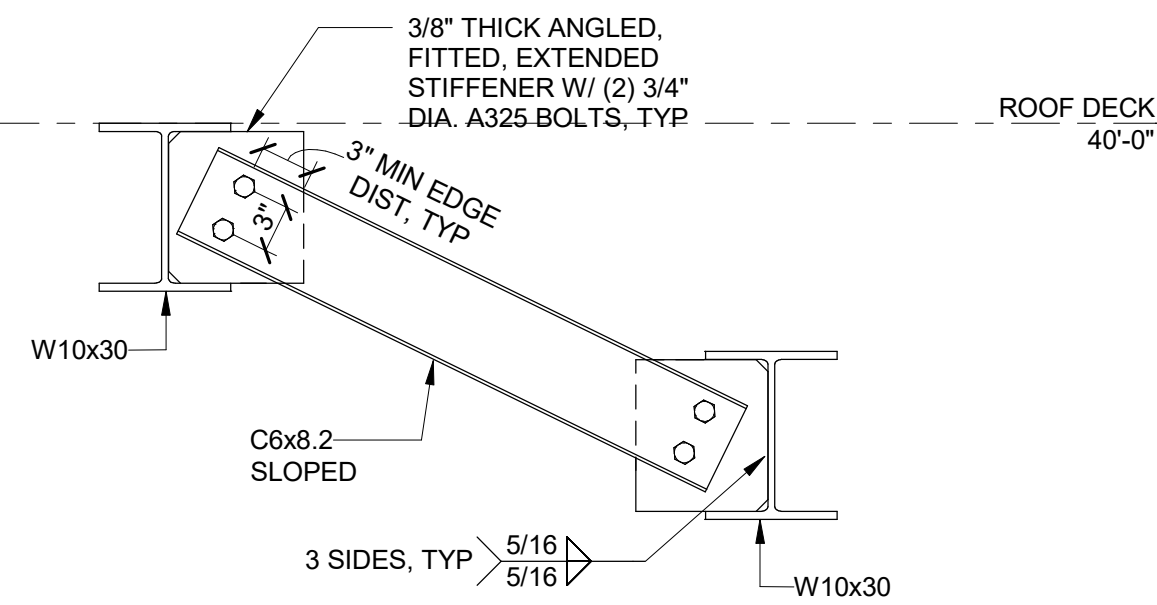

2 HORIZONTAL BRACE SLOPED
 1" = 1'-0"

Consultant

No.	Date	Description	By

GOULD RESIDENCE
 164 West Newton Street
 Boston, MA 02118

Project

Project No.
SECTIONS AND DETAILS

Drawing Title

Project No. 220288.00	Checked MAT	Date 04/19/22
Drawn MRM	Approved PJS	Scale 1" = 1'-0"

Drawing No.

S-201

Seal