

March 22, 2021

Environmental Department  
Boston City Hall, Room 709  
Boston, MA 02201

**RE: Landmarks Design Review – Boch Center, Wang Theatre Elevator Upgrade**

Dear Reviewers,

This letter and accompanying attachment are intended to provide an update to the original application for the Commission's Design Review of the Wang Theatre Elevator Upgrade dated December 28, 2020.

The updated content is intended to respond to Commission comments voiced during the public hearing and subsequent review sessions relating to the treatment of the replacement elevator entrance doors at the Orchestra (Main) and Mezzanine (Fourth) Levels. We believe we have responded to the concerns of the Commission in good faith, and hope that this additional material will provide you with a clearer understanding of the proposed work, and the necessary improvements to the Wang Theatre - Boston's important historic and cultural landmark.

Thank you for your time in reviewing these materials. Please do not hesitate to contact me if you have any questions or require additional information.

Sincerely,



**PAUL VAIVODA**, AIA, LEED AP BD+C, NCARB  
Principal

**Wilson Butler Architects**  
*architecture for arts and entertainment*

Attachments: Supportive Documentation Update – Existing Photos & Proposed Drawings (4 Pages)



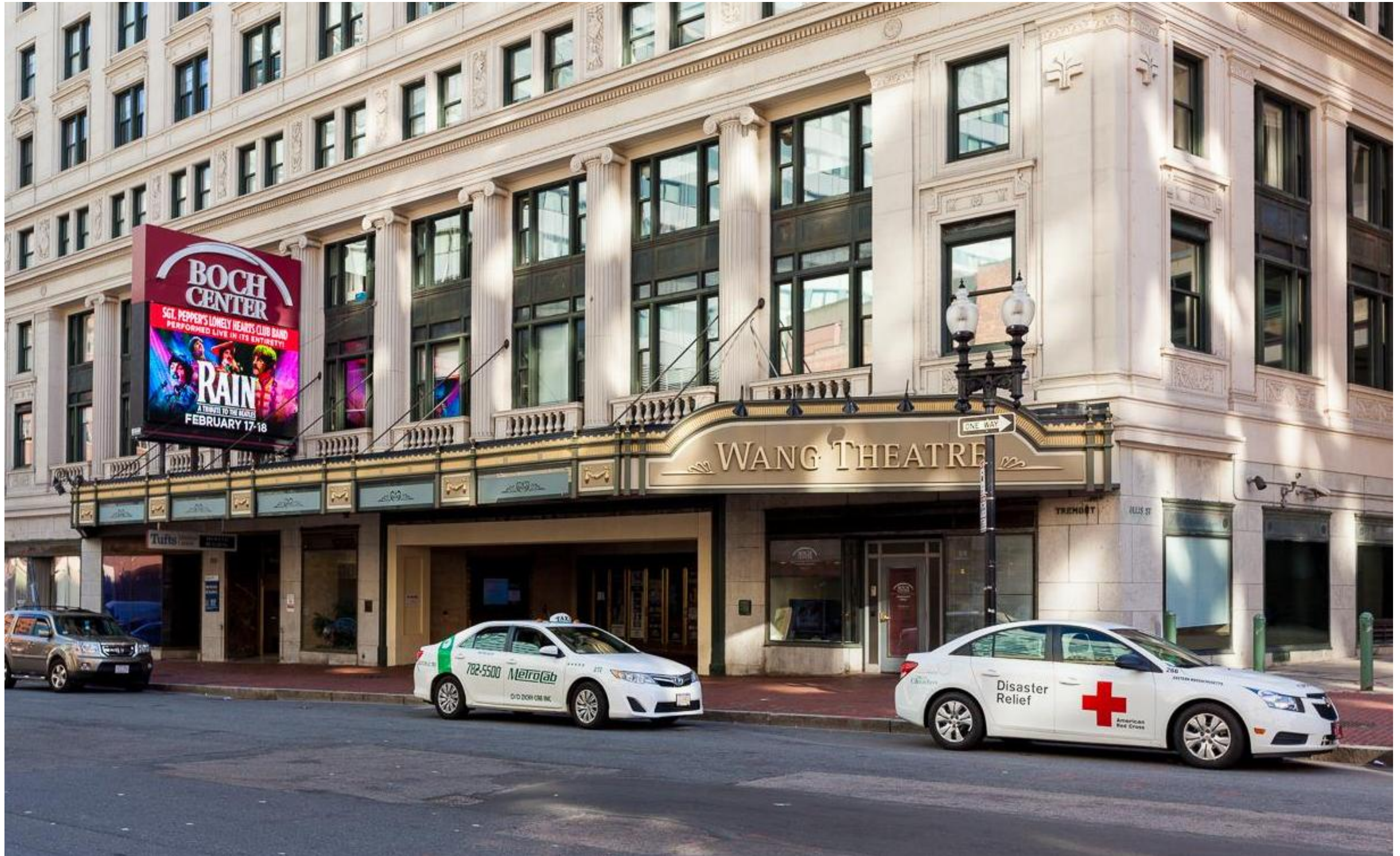

Wang Theater  
270 Tremont Street, Boston MA 02116

Boston Landmark Commission - Elevator Upgrade Review Application | Public Hearing - March 23, 2021

Sheet 1 of 4

**Wilson Butler Architects**



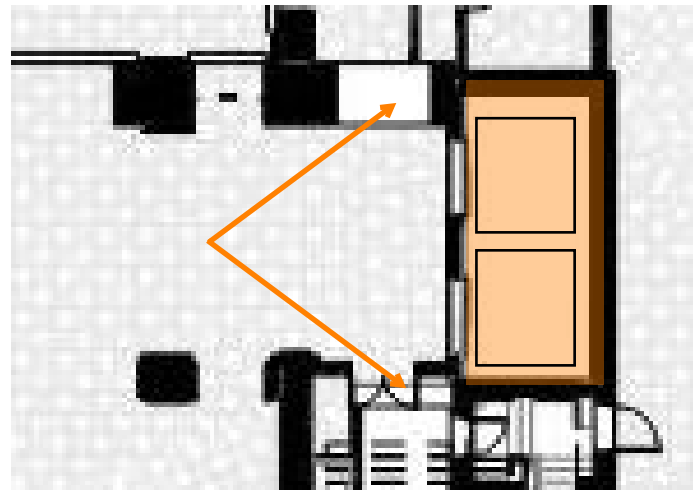

Partial Main/Orchestra Level Floor Plan

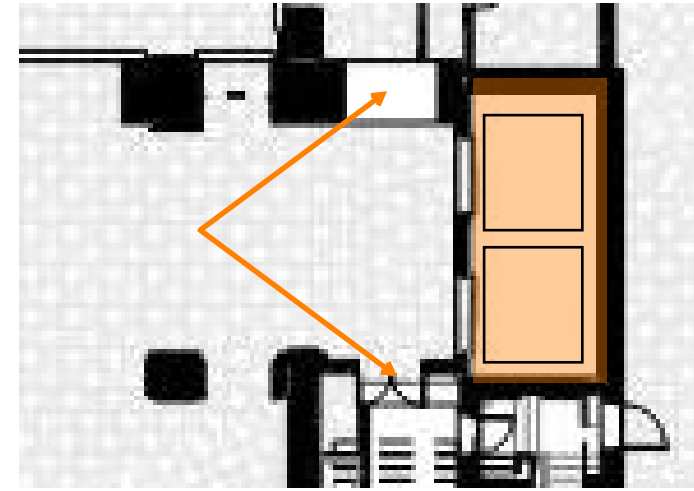

Partial Main/Orchestra Level Floor Plan



Existing



Originally Proposed

Orchestra/Main Level Elevator Lobby



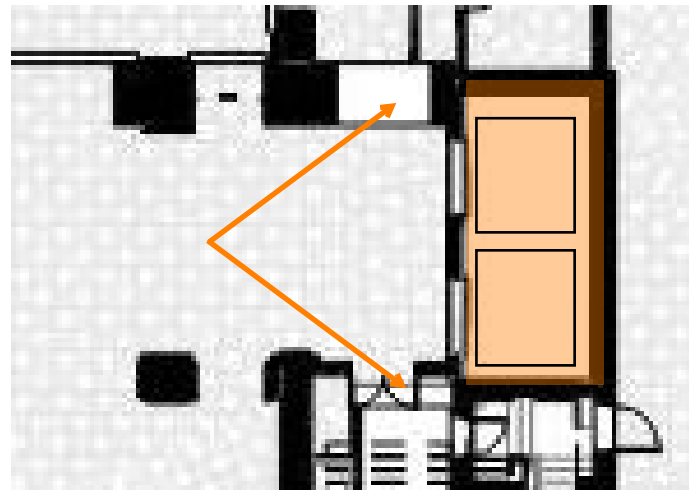

Partial Main/Orchestra Level Floor Plan



Existing Elevator Entrance Door Detail



Revised Elevator Entrance Door Material



Proposed Alternate

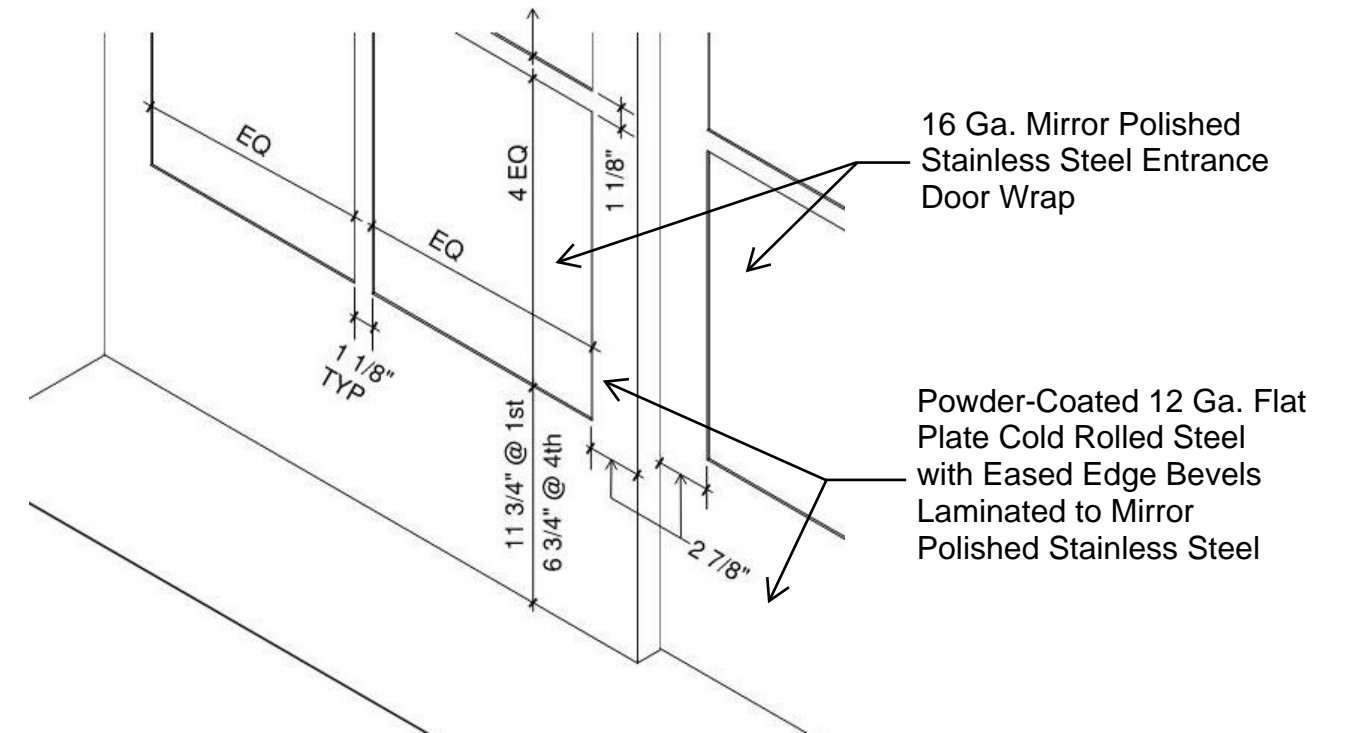

Revised Elevator Entrance Door Detail

Orchestra/Main Level Elevator Lobby



Wang Theater  
270 Tremont Street, Boston MA 02116

Boston Landmark Commission - Elevator Upgrade Review Application | Public Hearing - March 23, 2021

Sheet 3 of 4





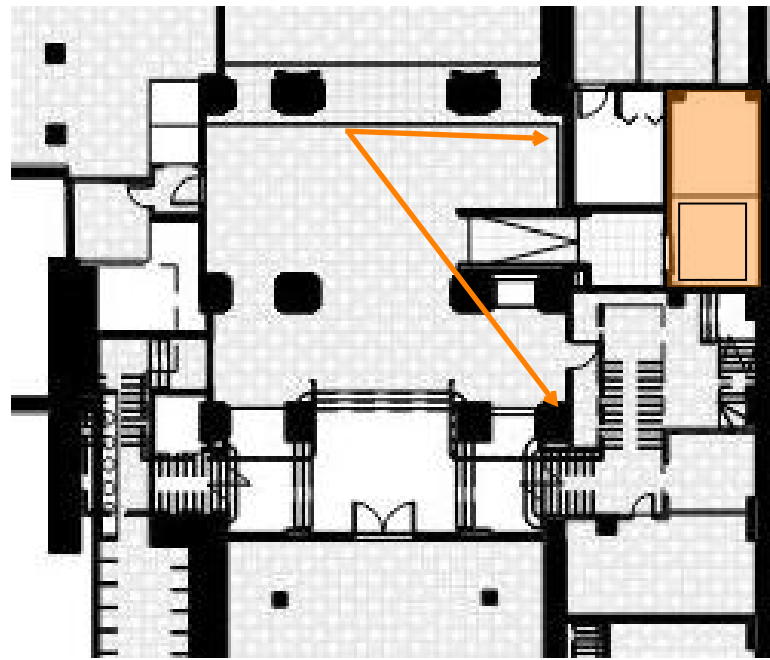

Partial Proposed Lower Level Floor Plan

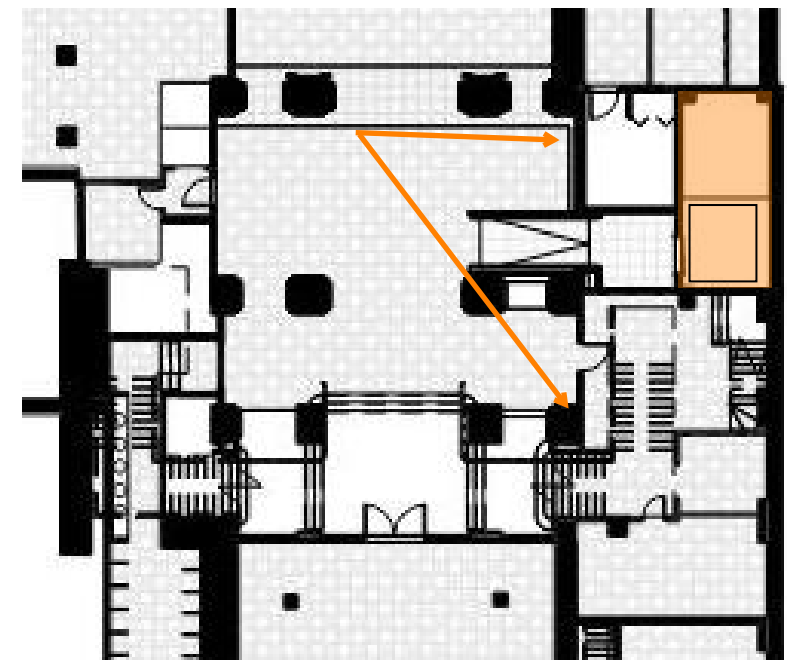

Partial Proposed Lower Level Floor Plan



Originally Proposed



Revised Proposed

Proposed ADA Ramp & Elevator Stop Beyond



Wang Theater  
270 Tremont Street, Boston MA 02116

Boston Landmark Commission - Elevator Upgrade Review Application | Public Hearing - March 23, 2021

Sheet 4 of 4

**Wilson Butler Architects**