

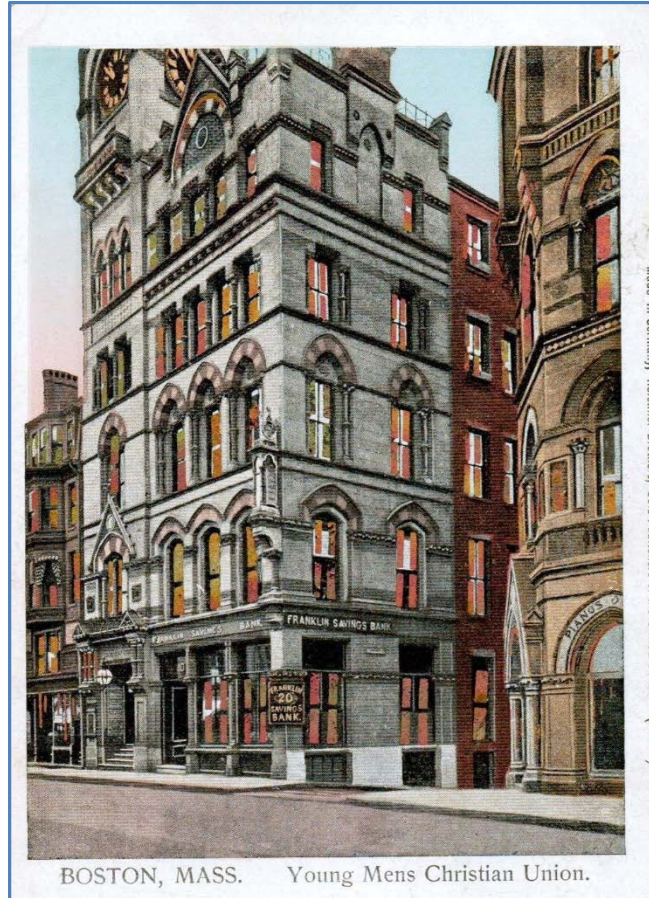

# The Union 48 Boylston Street

*Design Review – Signage and Awnings*

February 25, 2020



# The Union – Summary of Status

- August 2015 - Rehabilitation scope of work approved by BLC
- July 2017 – Approval extended
- July 2018 – Updated scope of work approved by BLC
- June 2019 – Ribbon-cutting
- August 2019 – Historic Tax Credit Part 3 certification
  - Upcoming:
  - Marty's Way entrance
  - Tenant fit-out (including signage)



# Signage (The Urban Hound)

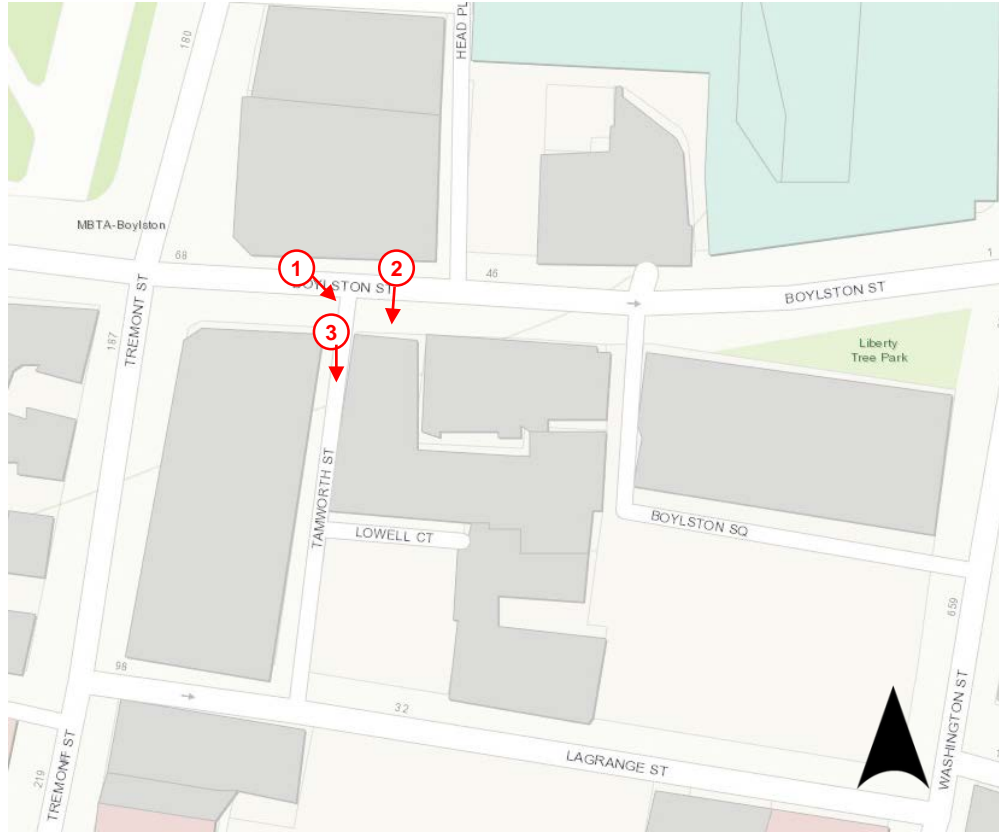

## The Union

48 Boylston Street



PHI DESIGN GROUP

# EXTERIOR SIGNAGE

# theurbanhound at St.FrancisHouse

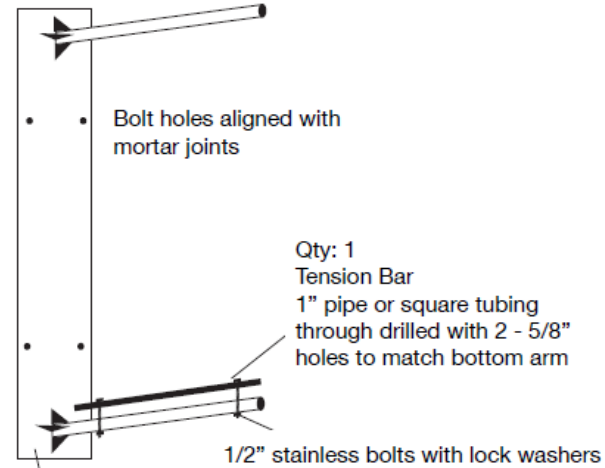
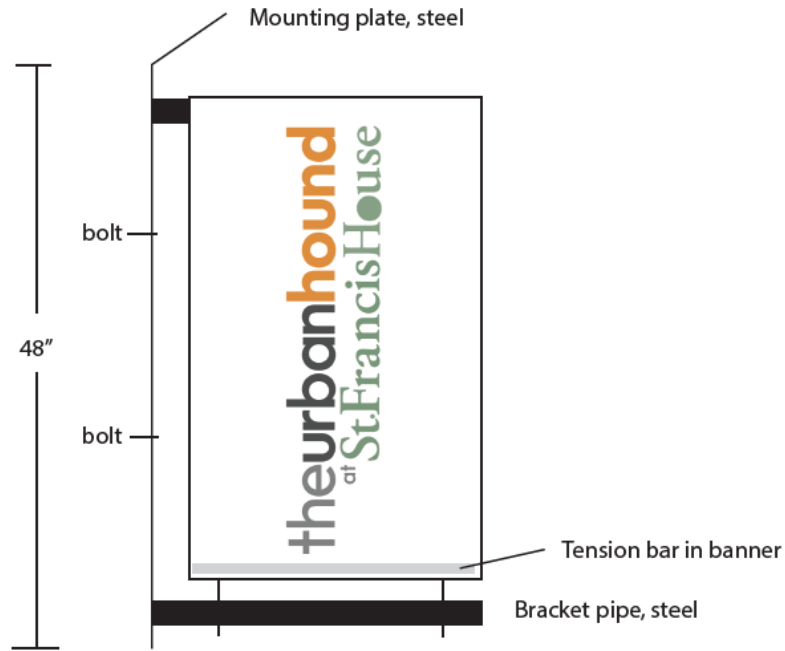

Qty: 1  
Milled Steel  
8" x 47" x .25" plate  
4 - 5/8" holes for bolts  
2 - 2" x 28" pipe arms, capped, with gussets  
bottom arm is through drilled with 2 - 5/8" holes



URBAN HOUND  
Banner and bracket  
Side view  
24" x 40" Sunbrella banner  
Digital cmyk printing

## The Union

48 Boylston Street

# Marty's Way Entrance

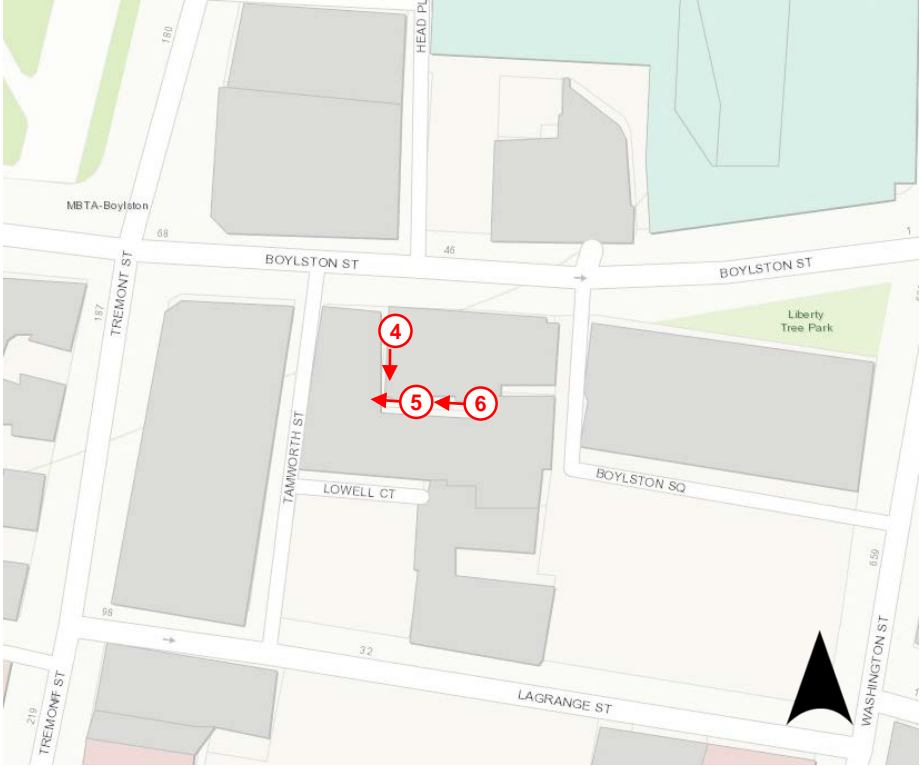

# The Union

48 Boylston Street



# Marty's Way Entrance (1/3)

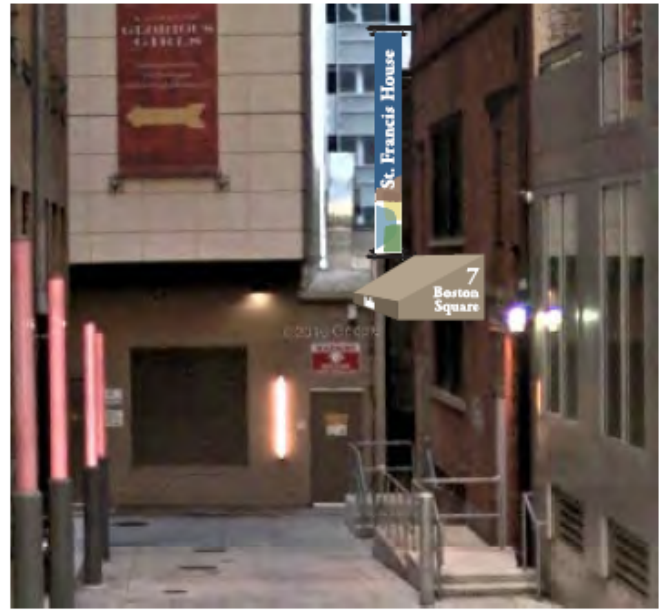
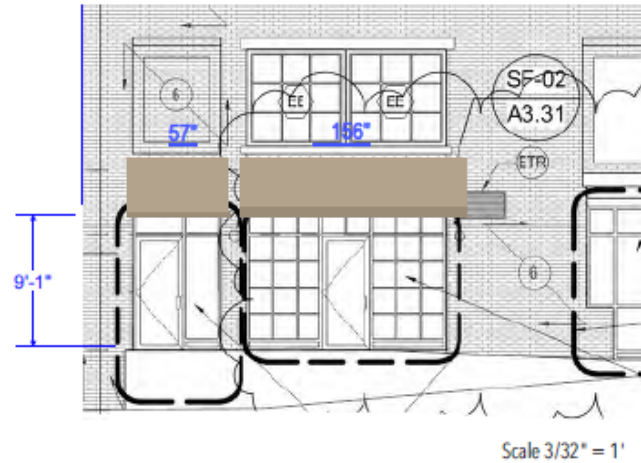
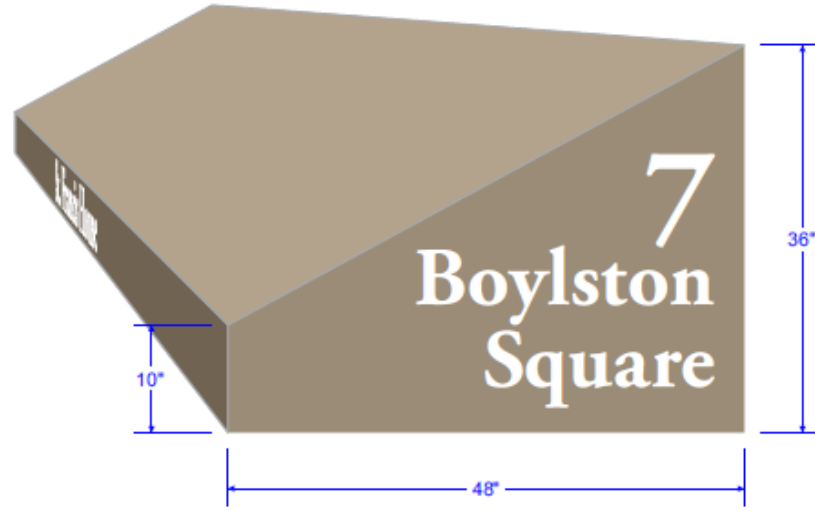

**St. Francis House**  
48 Boylston Street  
Boston, MA 02116

**Side Entrance Awning**  
Scale 1:16

**QUANTITY**  
1 awning.

**DESCRIPTION**  
Screen printed letters on Sunbrella fabric awning.  
Aluminum frame.

**MOUNTING**  
TBD.

**QUESTIONS/COMMENTS**  
*\*These are suggested dimensions only.*  
Other color options available below.

**COLORS**  
 Sunbrella Tresco Birch  
 White



[Other Sunbrella color options available here: https://www.sunbrella.com/en-us/fabrics/recommended-uses?shade=1](https://www.sunbrella.com/en-us/fabrics/recommended-uses?shade=1)

The Union  
48 Boylston Street



Production will not begin without a signed and checked approval on all final layouts and a signed proposal.  
Please proof this layout carefully, check the appropriate box, sign and date.  
Submit completed layout form to [info@MLGsigns.com](mailto:info@MLGsigns.com) or fax to 603-588-8302.  
SIGNED \_\_\_\_\_ DATE \_\_\_\_\_

- APPROVED
- CORRECTIONS (send new layout)
- REJECTED

RH/GP ©2018

**Questions?**  
Call MainLine Graphics at 603-588-3177 or email [info@MLGsigns.com](mailto:info@MLGsigns.com)  
  
All original artwork is the copyrighted property of MainLine Graphics, LLC, and all rights are reserved until services rendered to client are paid in full.

# Marty's Way Entrance (2/3)

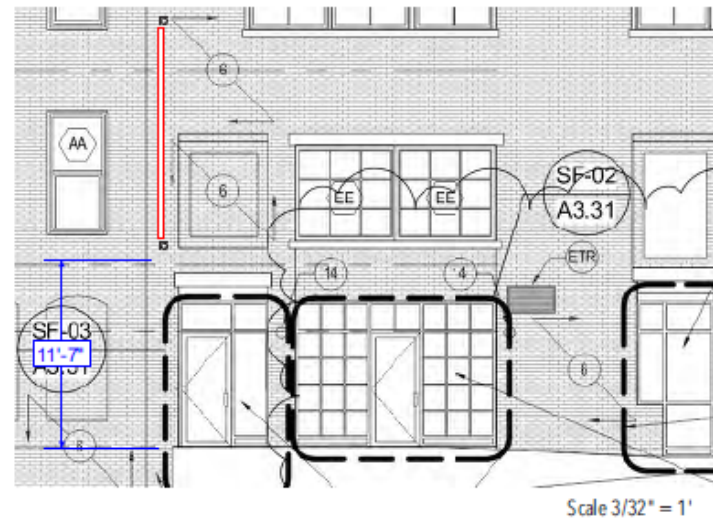
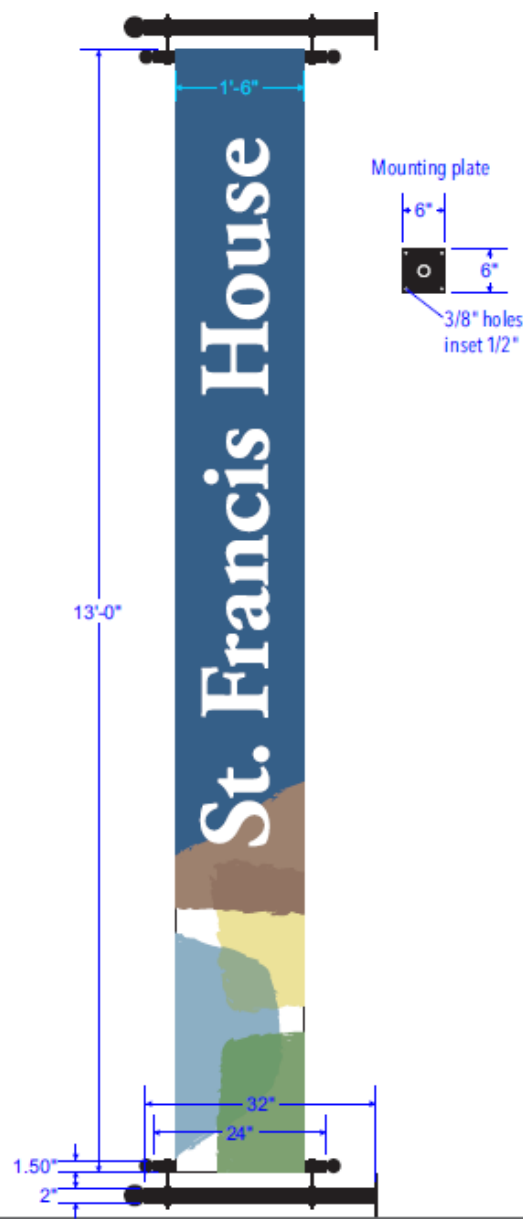

**St. Francis House**  
48 Boylston Street  
Boston, MA 02116

**Pole Banner**  
Scale 1/2" = 1'

**QUANTITY**  
1 single sided pole banner.

**DESCRIPTION**  
Fabric banner with printed image on one side.  
Steel "trapeze" style banner brackets with black powder coat finish.

**MOUNTING**  
Brackets mount to building with screws and epoxy.

**QUESTIONS/COMMENTS**

**COLORS**  
Full color print.

The Union  
48 Boylston Street



Production **will not** begin without a signed and checked approval on all final layouts and a signed proposal.

Please proof this layout carefully, check the appropriate box, sign and date.

Submit completed layout form to [info@MLGsigns.com](mailto:info@MLGsigns.com) or fax to 603-588-8302.

SIGNED \_\_\_\_\_ DATE \_\_\_\_\_

- APPROVED
- CORRECTIONS (send new layout)
- REJECTED

RH/GP  
©2018

**Questions?**  
Call MainLine Graphics at 603-588-3177  
or email [info@MLGsigns.com](mailto:info@MLGsigns.com)

All original artwork is the copyrighted property of MainLine Graphics, LLC, and all rights are reserved until services rendered to client are paid in full.

# Marty's Way Entrance (3/3)

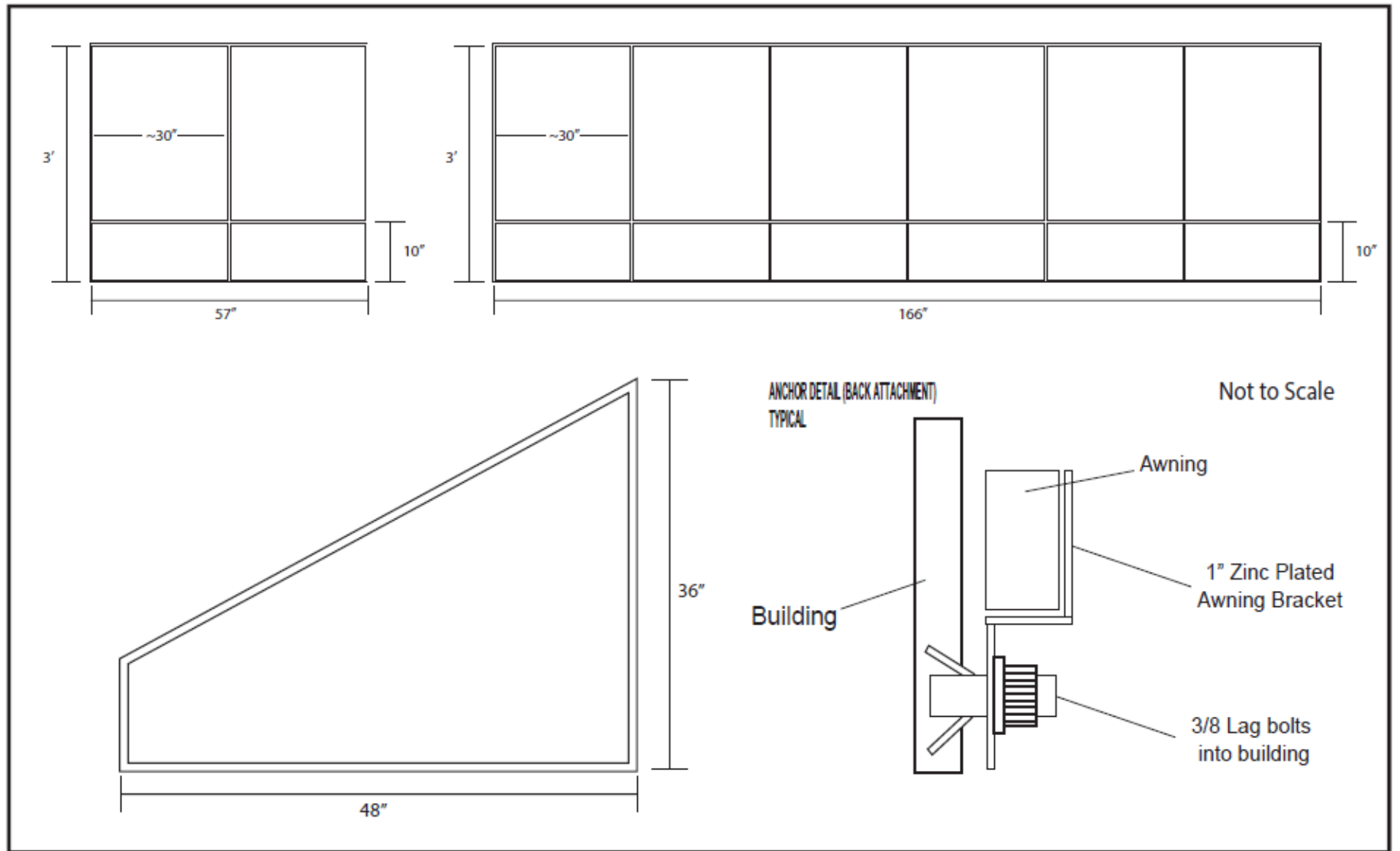

The Union  
48 Boylston Street



30 ALSTON STREET, SOMERVILLE, MA 02134  
(617) 776-7549

Project: St. Francis House		Location:	Job Description:	Revised
Salesman: Tony	Designer: Josh			
Scale:				
Date:	Sketch #:	File Name:		

Note: This is an original drawing created by and owned by Flagraphics, Inc. It is submitted for your personal use in connection with a project being planned for you by Flagraphics, Inc. It is not to be shown to anyone outside your organization, nor is it to be used, reproduced, copied, or exhibited in any fashion.

Customer Approval: