



boston planning & development agency

Boston Redevelopment Authority

Martin J. Walsh, Mayor of Boston

Brian Golden, Director

Board of Directors

- Timothy J. Burke, Chairman
- Priscilla Rojas, Vice Chairman
- Carol Downs, Treasurer
- Michael P. Monahan, Member
- Dr. Theodore C. Landsmark, Member
- Teresa Polhemus, Executive Director/Secretary

List of Drawings

- CS-1 Cover Sheet
- 1.0 GENERAL NOTES
- 2.0 AERIAL LOCATION PLAN
- 2.1 EXISTING CONDITIONS AND SITE PREPARATION PLAN
- 3.0 PROPOSED SITE PLAN
- 3.1 PROPOSED SECTIONS AND DETAILS
- 4.0 PROPOSED SITE RESTORATION PLAN

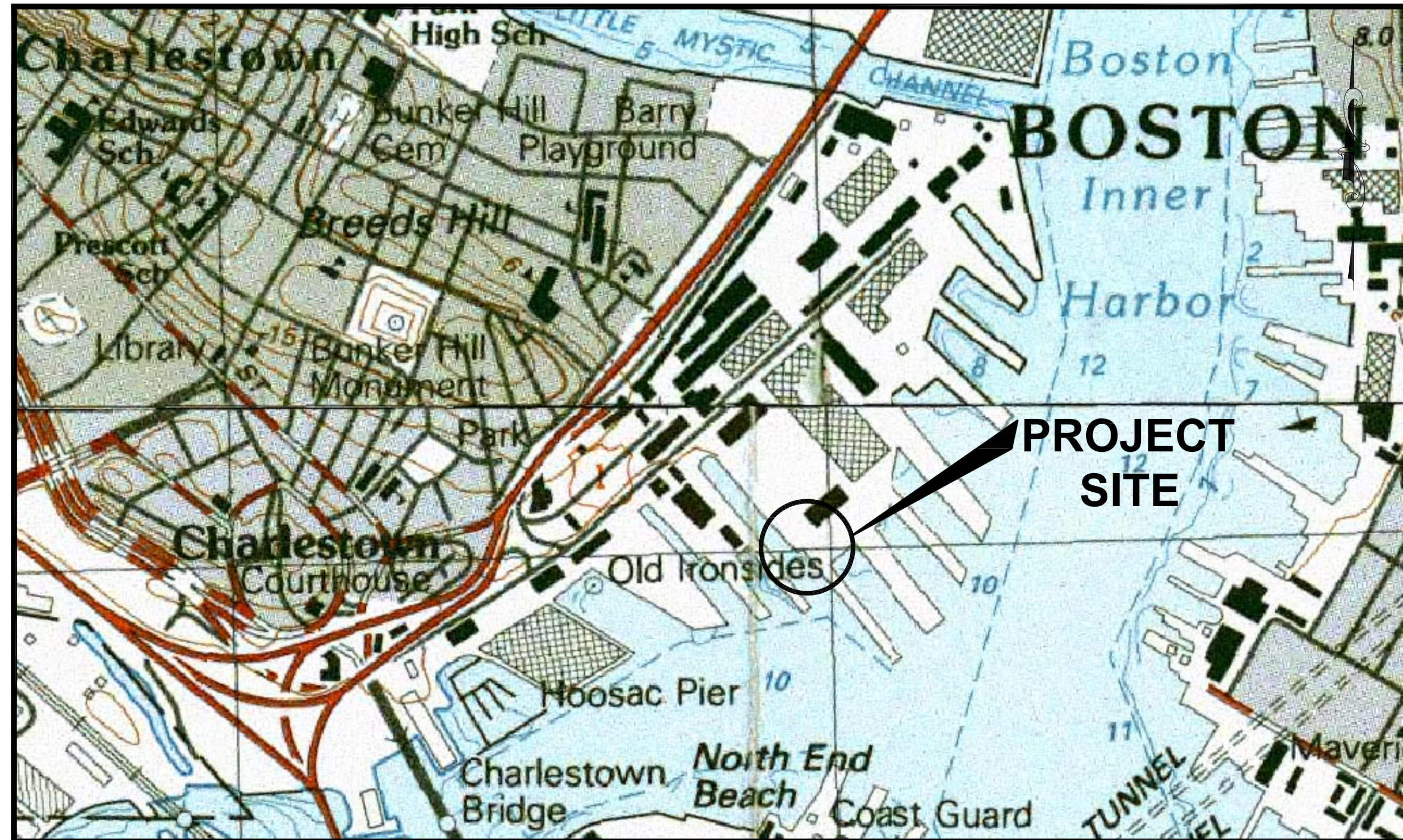

LOCATION PLAN

Prepared by:



Prepared for:

BPDA Capital Construction Dept.
22 Drydock Avenue, Suite 201
Boston, Massachusetts 02210

CONTRACT DOCUMENTS FOR:

PIER 4 CULVERT AND SINKHOLE REPAIRS CHARLESTOWN NAVY YARD, BOSTON, MA BRA PROJECT No. XXXX

FEBRUARY 2019

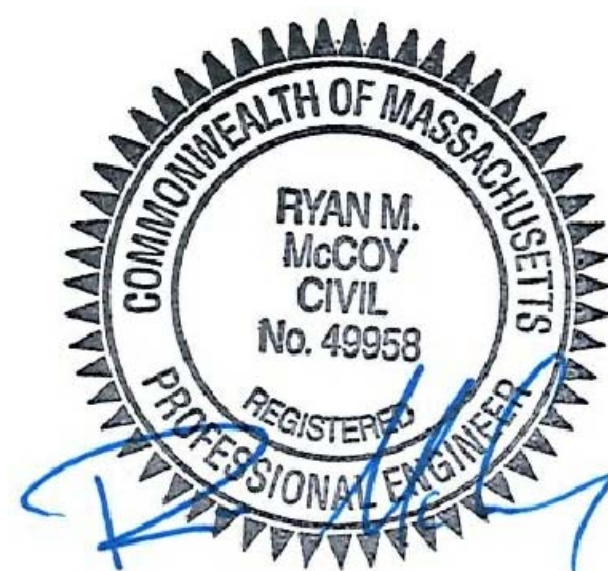

PERMIT SUBMISSION
NOT FOR CONSTRUCTION

GENERAL NOTES:

- FOR THE PURPOSE OF THIS PROJECT
OWNER – BOSTON PLANNING & DEVELOPMENT AGENCY (BPDA)
22 DRYDOCK AVENUE
BOSTON, MA 02210
ENGINEER – PARE CORPORATION
10 LINCOLN ROAD, SUITE 210
FOXBORO, MA 02035
CONTACT – RYAN MCCOY, PE
- VERTICAL DATUM: BOSTON CITY BASE – VIA RTK/GPS or MLW.
- EXISTING SITE PLAN DEVELOPED FROM AVAILABLE AERIAL IMAGERY FROM MASSGIS, PLAN SET TITLED "EXISTING CONDITIONS PLAN OF LAND IN BOSTON, (CHARLESTOWN) MASSACHUSETTS" DATED MARCH 17, 2015 AND PREPARED BY BRYANT ASSOCIATES, INC., AND PLAN SET TITLED "GENERAL BULKHEAD RESTORATION PLAN" DATED APRIL 21, 1981 AND PREPARED BY TIBBETTS ENGINEERING CORP. INFORMATION IS PROVIDED FOR REFERENCE PURPOSES ONLY.
- THE LINWORK REPRESENTING UNDERGROUND STRUCTURES AND PIPES HAVE BEEN SHOWN IN THEIR APPROXIMATE LOCATION BASED RECORD PLANS. THE UNDERGROUND UTILITIES SHOWN MAY NOT COMPRISE ALL SUCH UTILITIES IN THE AREA, EITHER IN SERVICE OR ABANDONED. THERE IS NO WARRANT THAT THE UNDERGROUND UTILITIES SHOWN ARE IN THE EXACT LOCATION INDICATED.
- ALL WORK SHALL CONFORM WITH APPLICABLE FEDERAL, STATE AND MUNICIPAL REGULATIONS, INCLUDING THE FEDERAL DEPARTMENT OF LABOR, OCCUPATIONAL SAFETY AND HEALTH ADMINISTRATION (OSHA) AND APPLICABLE SECTIONS OF THE INTERNATIONAL BUILDING CODE (IBC).
- CONTRACTOR SHALL ENSURE THAT ADEQUATE SHORING AND FALSEWORK ARE PROVIDED TO THE EXISTING STRUCTURE(S) RESULTING IN A STABLE AND SAFE STRUCTURE AT ALL TIMES. CONTRACTOR IS ADVISED THAT THE TIMBER PILES SUPPORTING THE EXISTING CONCRETE CULVERT, EXISTING STEEL SHEET PILES, WALLS, WALE, AND TIE RODS ARE DETERIORATED, THEREFORE THE STRUCTURAL CAPACITY OF THE RETAINING SYSTEM MAY BE REDUCED.
- IT IS THE CONTRACTOR'S RESPONSIBILITY TO PROVIDE PROPER DESIGN AND CONSTRUCTION OF FALSEWORK, FORMWORK, STAGING, BRACING, SHEETING, SHORING, TEMPORARY EARTH SUPPORTS, ETC. THAT AVOIDS EXCESSIVE DEFLECTION OR OVERSTRESSING OF THE STEEL SHEET PILES AND/OR WALE SYSTEM, AND SHALL BE STAMPED BY A LICENSED PROFESSIONAL ENGINEER REGISTERED IN THE COMMONWEALTH OF MASSACHUSETTS, AS REQUIRED.
- CONTRACTOR IS SOLELY RESPONSIBLE FOR MEANS, METHODS, AND SAFETY OF WORK.
- PROPER CONSTRUCTION AND TRAFFIC SIGNAGE SHALL BE INSTALLED AT OR NEAR THE PROJECT ENTRANCES(S). COORDINATE WITH LOCAL POLICE WHEN CONSTRUCTION VEHICLE ACTIVITIES COULD POTENTIALLY IMPEDE WITH NORMAL DAILY VEHICULAR AND/OR PEDESTRIAN TRAFFIC.
- PLANS AND SECTIONS ARE APPROXIMATE AND ARE TO BE USED FOR GENERAL LAYOUT. THE CONTRACTOR WILL BE RESPONSIBLE FOR MAKING FIELD MEASUREMENTS TO ASSURE CONSISTENCY WITH THE PROPOSED CONSTRUCTION PLANS. THE CONTRACTOR SHALL FIELD VERIFY ACTUAL CONDITIONS, DIMENSIONS, CLEARANCES, ELEVATIONS, AND OTHER INFORMATION INDICATED IN THE DOCUMENTS PRIOR TO ORDERING ANY MATERIALS, COMMENCING ANY FABRICATIONS, OR PERFORMING ANY WORK. THE CONTRACTOR SHALL NOTIFY THE ENGINEER OF ANY FIELD CONDITIONS WHICH MAY DIFFER FROM THAT REPRESENTED PRIOR TO COMMENCING WORK.
- PRIOR TO COMMENCING WORK, THE CONTRACTOR SHALL VISIT THE SITE AND SHALL NOTIFY THE ENGINEER OF ANY ADDITIONAL UTILITIES, STRUCTURES, OR ANY OTHER ELEMENTS WHICH MAY IMPEDE WORK. UTILITY AND/OR STRUCTURE RELOCATIONS, IF NECESSARY, SHALL BE COORDINATED THROUGH THE OWNER'S ENGINEER AT NO ADDITIONAL COST.
- PRIOR TO COMMENCING WORK, THE CONTRACTOR SHALL SCHEDULE AND COORDINATE ALL WORK THROUGH THE BPDA AND THE ENGINEER. THE CONTRACTOR SHALL COORDINATE THE WORK SO AS TO MINIMIZE INTERRUPTIONS IN NEARBY FACILITY OPERATIONS AND TOURISM.
- THE CONTRACTOR SHALL FULLY CORDON OFF THE WORK AREA TO PREVENT PUBLIC ACCESS. APPROXIMATE LOCATIONS OF SIGNAGE AND THE LIMITS OF SECURITY FENCING ARE SHOWN HEREIN.
- THE CONTRACTOR SHALL MAINTAIN A SECURE SITE AND PROVIDE APPROPRIATE SAFETY MEASURES TO PREVENT ACCIDENTS. SAFETY MEASURES SHALL INCLUDE, BUT NOT BE LIMITED TO SIGNAGE, BARRICADES, FENCING, FLASHING WARNING LIGHTS, AND POLICING.
- THE CONTRACTOR SHALL COMPLY WITH ALL APPLICABLE OSHA REGULATIONS AND SAFETY PROCEDURES TO ENSURE PERSONAL HEALTH AND SAFETY. THE CONTRACTOR MUST MAINTAIN A SAFE AND CLEAN WORKING ENVIRONMENT AND SHALL ASSURE PERSONAL PROTECTIVE EQUIPMENT (PPE) AT ALL TIMES.
- THE CONTRACTOR SHALL EXERCISE EXTREME CARE TO PREVENT DAMAGE TO EXISTING STRUCTURES BY OR AS A RESULT OF HIS OPERATIONS. ANY DAMAGE RESULTING FROM THE CONTRACTOR'S OPERATIONS SHALL BE REPAIRED AS DIRECTED BY THE OWNER'S REPRESENTATIVE AT NO ADDITIONAL COST TO THE OWNER.
- THE CONTRACTOR SHALL TAKE ALL NECESSARY PRECAUTIONS TO PREVENT ALL CONSTRUCTION DEBRIS OR WASTE FROM FALLING INTO THE WATERWAY. ANY DEBRIS FALLING INTO THE WATER SHALL BE RECOVERED AND PROPERLY DISPOSED OF.
- NOTES, TYPICAL DETAILS, AND SCHEDULES APPLY TO ALL WORK UNLESS OTHERWISE NOTED. FOR CONDITIONS NOT SPECIFICALLY SHOWN, PROVIDE DETAILS OF SIMILAR NATURE. VERIFY APPLICABILITY BY SUBMITTING SHOP DRAWINGS FOR REVIEW.
- THE CONTRACTOR SHALL STAGE ALL EQUIPMENT IN THE DESIGNATED STAGING AREA. ALL NECESSARY MEASURES SHALL BE TAKEN TO PREVENT BY ANY METHOD, OIL, CONSTRUCTION DEBRIS, STOCKPILED MATERIALS, AND OTHER MATERIALS ON THE SITE FROM ENTERING THE WATERWAY. STAGING/LAYDOWN AREAS, AS APPROVED BY THE ENGINEER, SHALL BE RESTORED BY THE CONTRACTOR TO THE EXISTING CONDITION. IN ADDITION, THE CONTRACTOR SHALL REPLACE ALL DAMAGED MATERIALS AS A RESULT OF HIS OPERATIONS, TO THE SATISFACTION OF THE ENGINEER AT NO ADDITIONAL COST TO THE OWNER.
- SHOP AND ERECTION DRAWINGS FOR ALL WORK SHALL BE SUBMITTED TO THE ENGINEER FOR REVIEW AND APPROVAL AS PER THE SPECIFICATIONS. FABRICATION OF THESE ITEMS SHALL NOT COMMENCE WITHOUT APPROVED SHOP DRAWINGS. SHOP DRAWINGS ARE PREPARED AND USED BY THE CONTRACTOR AS INSTRUMENTS TO SEQUENCE HIS WORK AND TO FACILITATE FABRICATION AND ERECTION. REVIEW OF SHOP DRAWINGS SHALL BE FOR GENERAL DETAIL AND ARRANGEMENT ONLY. CONTRACTOR SHALL BEAR FULL RESPONSIBILITY FOR DIMENSIONS, PROPER FIT, AND DETAILED DESIGN OF CONNECTIONS. THEIR APPROVAL BY THE ENGINEER IS NOT TO BE CONSTRUED AS A WAIVER OF CONSTRUCTION CONTRACT REQUIREMENTS OR RESPONSIBILITIES, UNLESS THE CONTRACTOR HAS BEEN GRANTED A DEVIATION IN WRITING.
- IN CASE OF CONTRADICTION BETWEEN THE DRAWINGS, THE SPECIFICATIONS, AND THE CODES, OR IF ANY CHANGE IS REQUIRED, THE CONTRACTOR SHALL INFORM THE ENGINEER IMMEDIATELY. NO CHANGE SHALL BE MADE WITHOUT WRITTEN APPROVAL OF THE ENGINEER.

EROSION CONTROL NOTES:

- CONTRACTOR SHALL MAINTAIN ALL EROSION CONTROL DEVICES FOR THE DURATION OF THE PROJECT.
- CONTRACTOR SHALL PREVENT SEDIMENT FROM ENTERING THE HARBOR VIA DISCHARGES THROUGH ANY DRAINAGE STRUCTURES OR RUNOFF FROM WITHIN THE LIMITS OF WORK.
- CONTRACTOR SHALL BE RESPONSIBLE FOR REMOVING, RESTORING AND REPAIRING ALL DAMAGE AS A RESULT OF UNAUTHORIZED WORK OR DISCHARGES AT NO ADDITIONAL COST TO THE OWNER.
- THE CONTRACTOR SHALL INSTALL AND MAINTAIN TURBIDITY BARRIERS AS INDICATED IN THE CONTRACT DOCUMENTS. TURBIDITY BARRIERS SHALL BE ANCHORED SECURELY AS NECESSARY TO ENSURE COLLECTION OF SEDIMENT AND ENABLE THE WORK TO BE PERFORMED.
- THE TURBIDITY BARRIER SHALL BE INSTALLED PRIOR TO COMMENCEMENT OF WORK AND SHALL REMAIN IN PLACE UNTIL ALL WORK IS COMPLETED, AS APPROVED BY THE ENGINEER.
- SOIL STOCKPILES SHALL BE A MINIMUM OF 2- FEET FROM THE EDGE OF THE BULKHEAD TO LIMIT RUNOFF INTO THE WATERWAY.
- EROSION CONTROL BARRIERS SHALL BE MODIFIED OR EXPANDED AS FIELD CONDITIONS WARRANT.
- ALL EROSION CONTROL BARRIERS SHALL BE INSPECTED AT LEAST ONCE PER WEEK. ANY DAMAGED AREAS OF THE EROSION CONTROL BARRIER SHALL BE REPAIRED WITHIN 24 HOURS OF DISCOVERY.
- DEWATERING BASINS SHALL CONSIST OF HAY BALE ENCLOSURES, TANKS, PERMEABLE BLADDERS, OR OTHER APPROPRIATE METHOD. DEWATERING WASTE WATERS SHALL BE PUMPED TO THE DEWATERING BASINS AND TREATED PRIOR TO DISCHARGE.
- DISCHARGE OF TURBID WATER TO THE WATERWAY SHALL BE PROHIBITED.

SPILL PREVENTION AND CONTROL NOTES:

- SPILLS AND LEAKS SHALL BE AVOIDED THROUGH FREQUENT INSPECTION OF EQUIPMENT AND MATERIAL STORAGE AREAS.
- HEAVY EQUIPMENT AND OTHER VEHICLES SHALL BE ROUTINELY INSPECTED FOR LEAKS AND REPAIRED AS NECESSARY.
- HAZARDOUS MATERIAL STORAGE TO BE PLACED ONLY IN DESIGNATED AREAS. MATERIAL STORAGE AREAS SHALL BE ROUTINELY INSPECTED FOR LEAKY CONTAINERS, OPEN CONTAINERS, OR IMPROPER STORAGE TECHNIQUES THAT MAY LEAD TO SPILLS OR LEAKS.
- APPROPRIATE SPILL REMEDIATION PROCEDURES AND SUPPLIES SHALL BE READILY AVAILABLE ON-SITE. TOOLS AND SUPPLIES SHALL BE CLEARLY MARKED SO THAT ALL PERSONNEL CAN LOCATE AND ACCESS THESE SUPPLIES.
- SPILL REMEDIATION SHALL BE PERFORMED IMMEDIATELY. CONTRACTOR SHALL FOLLOW PROPER RESPONSE PROCEDURES IN ACCORDANCE WITH ANY APPLICABLE REGULATORY REQUIREMENTS.
- AT NO TIME SHALL SPILLS BE DIVERTED TOWARD STORM DRAINS OR TO THE HARBOR.
- EQUIPMENT/VEHICLE FUELING AND REPAIR/MAINTENANCE OPERATIONS SHALL TAKE PLACE ONLY WITHIN DESIGNATED STAGING AREAS.
- THE EQUIPMENT OPERATOR SHALL FULLY MONITOR FUELING OPERATIONS TO EQUIPMENT AND VEHICLES AT ALL TIMES.
- ANY SPILLAGE SHALL BE IMMEDIATELY CLEANED WITH SPILL KITS KEPT ON SITE.
- IN THE CASE OF SMALL AMOUNTS OF SOIL CONTAMINATION, SUCH SOIL SHALL BE PLACED IN 55 GALLON DRUMS FOR DISPOSAL BY A LICENSED HAZARDOUS WASTE HAULER.
- IN THE CASE OF A LARGE AMOUNT OF SOIL CONTAMINATION OR DISCHARGE TO THE HARBOR, MASSACHUSETTS DEP AND APPLICABLE AGENCIES SHALL BE NOTIFIED AS NECESSARY. A HAZARDOUS WASTE REMEDIATION FIRM SHALL BE CONTRACTED TO REMOVE AND DISPOSE OF THE CONTAMINATED MATERIAL OR CONTAIN THE SPILL AT NO ADDITIONAL COST TO THE OWNER.

DEMOLITION NOTES

- THE CONTRACTOR IS RESPONSIBLE FOR VERIFYING ALL EXISTING CONDITIONS IN THE FIELD PRIOR TO ANY DEMOLITION OR CONSTRUCTION. ANY DISCREPANCIES RELATING TO THE DRAWINGS SHALL BE REPORTED TO THE ENGINEER IMMEDIATELY.
- CONTRACTOR TO BE AWARE OF SELECTIVE DEMOLITION AT ALL SECTIONS OF WORK. CONTRACTOR SHALL BE RESPONSIBLE FOR REPLACEMENT IN-KIND OF ALL WORK INADVERTENTLY REMOVED AT NO ADDITIONAL COST TO THE OWNER.
- THE CONTRACTOR SHALL REMOVE ITEMS TO BE DEMOLISHED AS INDICATED ON THE DRAWINGS WITH CARE AND NOT TO DAMAGE ADJACENT STRUCTURES. THE WORK AREA SHALL BE LEFT READY TO RECEIVE NEW WORK.
- THE CONTRACTOR SHALL BE RESPONSIBLE FOR OFFSITE DISPOSAL OF ALL PROJECT DEMOLITION MATERIAL, TRASH, AND DEBRIS IN ACCORDANCE WITH LOCAL AND STATE LAWS.

CONCRETE NOTES:

- CONCRETE WORK SHALL CONFORM TO THE LATEST EDITION OF ACI 318 – "BUILDING CODE REQUIREMENTS FOR STRUCTURAL CONCRETE" AND THE MASSACHUSETTS STATE BUILDING CODE.
- CONCRETE SHALL BE PROPORTIONED, MIXED, AND PLACED UNDER THE SUPERVISION OF THE APPROVED TESTING AGENCY.
- CONCRETE SHALL BE NORMAL WEIGHT, WITH TYPE II CEMENT, AND SHALL HAVE A MINIMUM COMPRESSIVE STRENGTH AT 28 DAYS OF 4,000 PSI 3/4" AGGREGATE-TYPICAL. ALL CONCRETE DESIGN MIXES SHALL BE SUBMITTED TO THE ENGINEER FOR REVIEW AND APPROVAL.
- ALL CONCRETE SHALL BE AIR-ENTRAINED WITH AN AIR CONTENT OF 6% +/- 1%.
- ALL EXPOSED EDGES SHALL BE CHAMFERED 1" UNLESS NOTED OTHERWISE.
- WHEN CONCRETE IS PLACED AGAINST PREVIOUSLY HARDENED CONCRETE, THE INTERFACE SHALL BE CLEAN, FREE OF LAITANCE AND INTENTIONALLY ROUGHENED TO FULL AMPLITUDE OF APPROXIMATELY 1/4 INCH.
- CONCRETE WASHOUT OPERATIONS TO OR WITHIN HARBOR MUST NOT TAKE PLACE AT ANY TIME.
- PRESSURES DUE TO PLACEMENT OF CONCRETE MUST BE LIMITED TO AVOID EXCESSIVE DEFLECTION OR OVERSTRESS OF THE SHEET PILES AND/OR WALE SYSTEM. REFERENCE ACI 347 – "GUIDE TO FORMWORK FOR CONCRETE" REQUIREMENTS.
- THE DETAILS SHOWN ARE BASED ON A CONCRETE POUR RATE OF 4 FEET PER HOUR WITH A LIFT HEIGHT NOT EXCEEDING 5 FEET DURING A 12 HOUR PERIOD. CONTRACTOR SHALL MONITOR PLACEMENT OF CONCRETE TO ENSURE 5 FOOT HEIGHT LIMIT IS NOT EXCEEDED. CONTRACTOR SHALL SUBMIT FALSEWORK DESIGN CALCULATIONS TO THE ENGINEER FOR APPROVAL.

REINFORCING STEEL NOTES:

- REINFORCING BARS SHALL BE DETAILED IN ACCORDANCE WITH ACI 315 – "DETAILS AND DETAILING OF CONCRETE REINFORCEMENT" AND THE MASSACHUSETTS STATE BUILDING CODE.
- COMPLETE SHOP DRAWINGS AND SCHEDULES OF ALL REINFORCING STEEL SHALL BE PREPARED BY THE CONTRACTOR AND SUBMITTED TO THE ENGINEER FOR APPROVAL PRIOR TO COMMENCEMENT OF THAT PORTION OF THE WORK. ALL ACCESSORIES MUST BE SHOWN ON THE SHOP DRAWINGS.
- REINFORCING BARS SHALL CONFORM TO ASTM A615 OR A706 (WELDABLE) GRADE 60.
- ALL SUPPORTS SUCH AS CHAIRS, BOLSTERS, SPACERS, BLOCKS AND HANGERS SHALL BE OF NON-CORROSIVE MATERIAL. BLOCKS SHALL BE MADE OF 4,000 PSI (UN-REINFORCED) CONCRETE.
- UNLESS NOTED ON THE DRAWINGS, THE MINIMUM CONCRETE PROTECTION (CLEAR COVER) FOR CAST-IN-PLACE CONCRETE COVER SHALL BE AS FOLLOWS:
A. FORMED CONCRETE EXPOSED TO EARTH OR WATER: 3"
B. CONCRETE CAST AGAINST AND PERMANENTLY EXPOSED TO EARTH: 3"
- MINIMUM REINFORCEMENT DEVELOPMENT LENGTH SHALL BE IN ACCORDANCE WITH ACI 318 UNLESS NOTED ON THE DRAWINGS. LAP SPLICE LENGTHS SHALL BE IN ACCORDANCE WITH ACI 318 FOR CLASS B LAPPS UNLESS NOTED OTHERWISE.
- WELDED WIRE FABRIC (WWF) SHALL CONFORM TO ASTM A185 OR A706 AND SHALL BE SUPPLIED IN FLAT SHEETS ONLY. SPLICES OF WWF SHALL BE AT LEAST 12 INCHES. WELDING OF REINFORCING BARS SHALL CONFORM TO AWS 1.4 – "STRUCTURAL WELDING CODE – REINFORCING STEEL"
- ALL REINFORCEMENT SHALL BE CONTINUOUS THROUGH CONSTRUCTION JOINTS. UNLESS NOTED OTHERWISE, BARS SHALL BE CONTINUOUS AND SHALL RUN CONTINUOUSLY AROUND CORNERS AND LAPPED AT NECESSARY SPLICES OR HOOKED AT DISCONTINUOUS ENDS.

WELDING NOTES:

- ALL WELDING SHALL BE IN ACCORDANCE WITH AWS D1.1 AND AWS D1.4.
- CLEAN AND INSPECT EXISTING MATERIAL PRIOR TO WELDING OF NEW MATERIAL. EXISTING MATERIAL SHALL BE TESTED FOR WELDABILITY TO NEW MATERIAL.
- EXISTING MATERIAL SHALL BE PRE-HEATED IN ACCORDANCE WITH AWS D1.1.
- ALL ELECTRODES SHALL BE E60 OR E70.
- FIELD WELDS SHALL BE INSPECTED BY AWS QUALIFIED PERSONNEL.

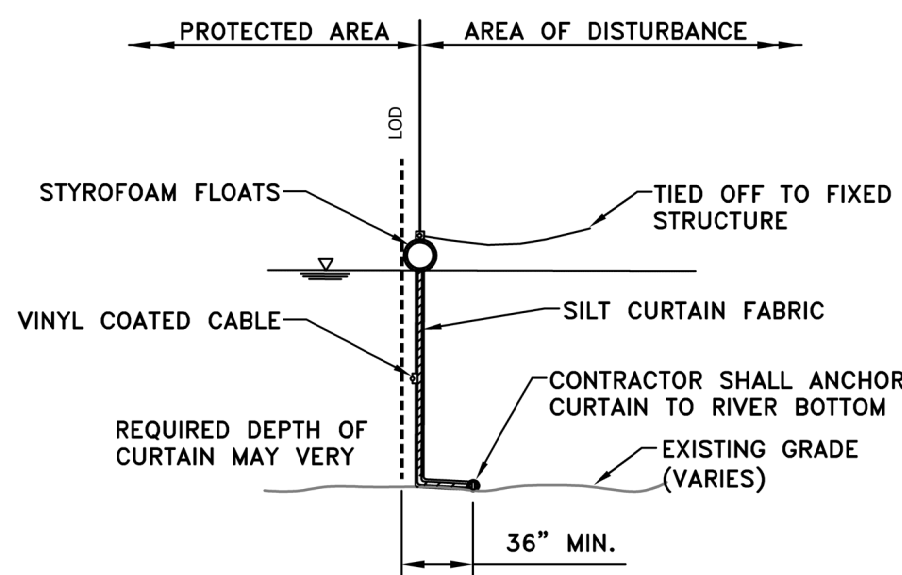

TYPICAL TURBIDITY BARRIER
NOT TO SCALE

LEGEND:

	EXISTING ELEVATION
	SPOT ELEVATION
	DRAIN LINE
	SEWER LINE
	ELECTRIC LINE
	TELEPHONE LINE
	MANHOLE
	WATER VALVE
	LIGHT POST

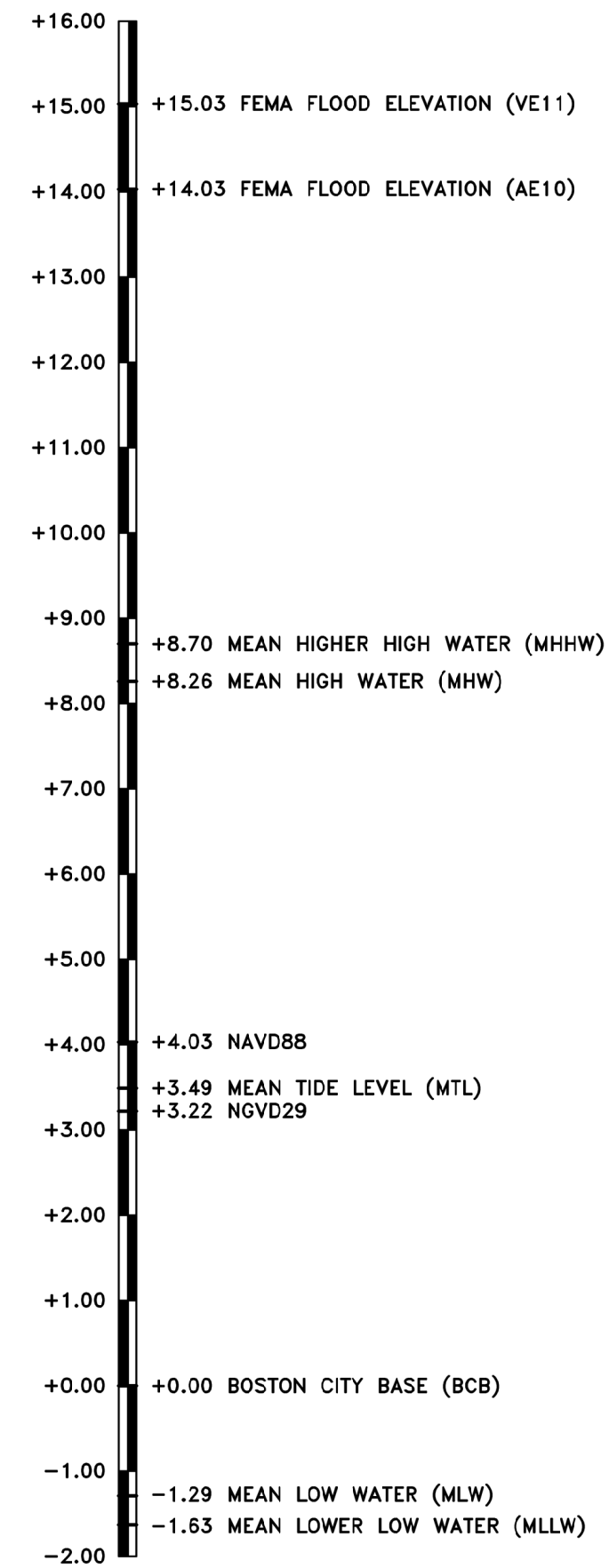

DATUM INFORMATION

BOSTON, MA 8443970
PID: MY0555 VM: 185

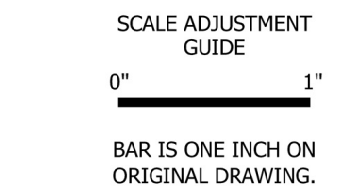

PIER 4 CULVERT AND SINKHOLE REPAIRS

CHARLESTOWN NAVY YARD
BOSTON, MASSACHUSETTS
BOSTON PLANNING AND DEVELOPMENT AGENCY



REVISIONS:

PROJECT NO.:	18228.00
DATE:	FEBRUARY 2019
SCALE:	AS NOTED
DESIGNED BY:	DJG
CHECKED BY:	RMM
DRAWN BY:	LMC/DJG
APPROVED BY:	RMM

GENERAL NOTES

SHEET NO.:

1.0

PERMIT SUBMISSION
NOT FOR CONSTRUCTION

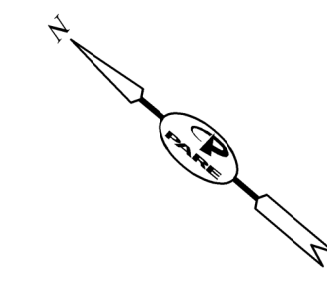

SCALE: 1"=150'

SCALE ADJUSTMENT
 GUIDE
 0" 1"
 BAR IS ONE INCH ON
 ORIGINAL DRAWING.

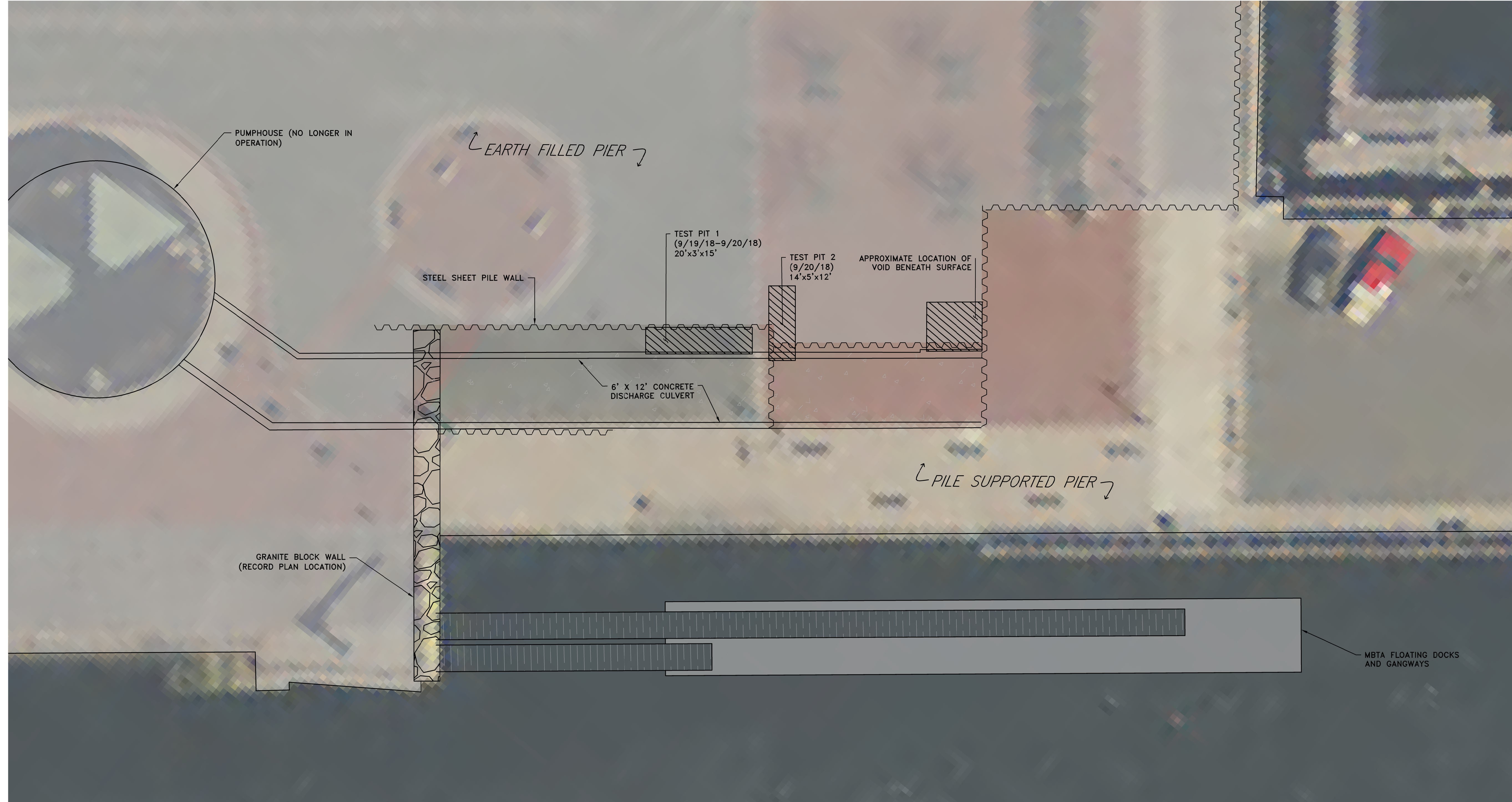

PIER 4 CULVERT AND SINKHOLE REPAIRS

CHARLESTOWN NAVY YARD
 BOSTON, MASSACHUSETTS
 BOSTON PLANNING AND DEVELOPMENT AGENCY



REVISIONS:

PROJECT NO.: 18228.00
 DATE: FEBRUARY 2019
 SCALE: AS NOTED
 DESIGNED BY: DJG
 CHECKED BY: RMM
 DRAWN BY: LMC/DJG
 APPROVED BY: RMM

AERIAL LOCATION PLAN

SHEET NO.: 2.0

AERIAL LOCATION PLAN
 SCALE: 1"=10'±

PERMIT SUBMISSION
 NOT FOR CONSTRUCTION

Y:\065\18 Jobs\18228.00 BPOA - Charlestown Pier 4 Sinkhole - MA\DWG\2.0 AERIAL PLAN.dwg



REVISIONS:

PROJECT NO.: 18228.00
 DATE: FEBRUARY 2019
 SCALE: AS NOTED
 DESIGNED BY: DJG
 CHECKED BY: RMM
 DRAWN BY: LMC/DJG
 APPROVED BY: RMM

EXISTING CONDITIONS AND SITE PREP PLAN

SHEET NO.: 2.1

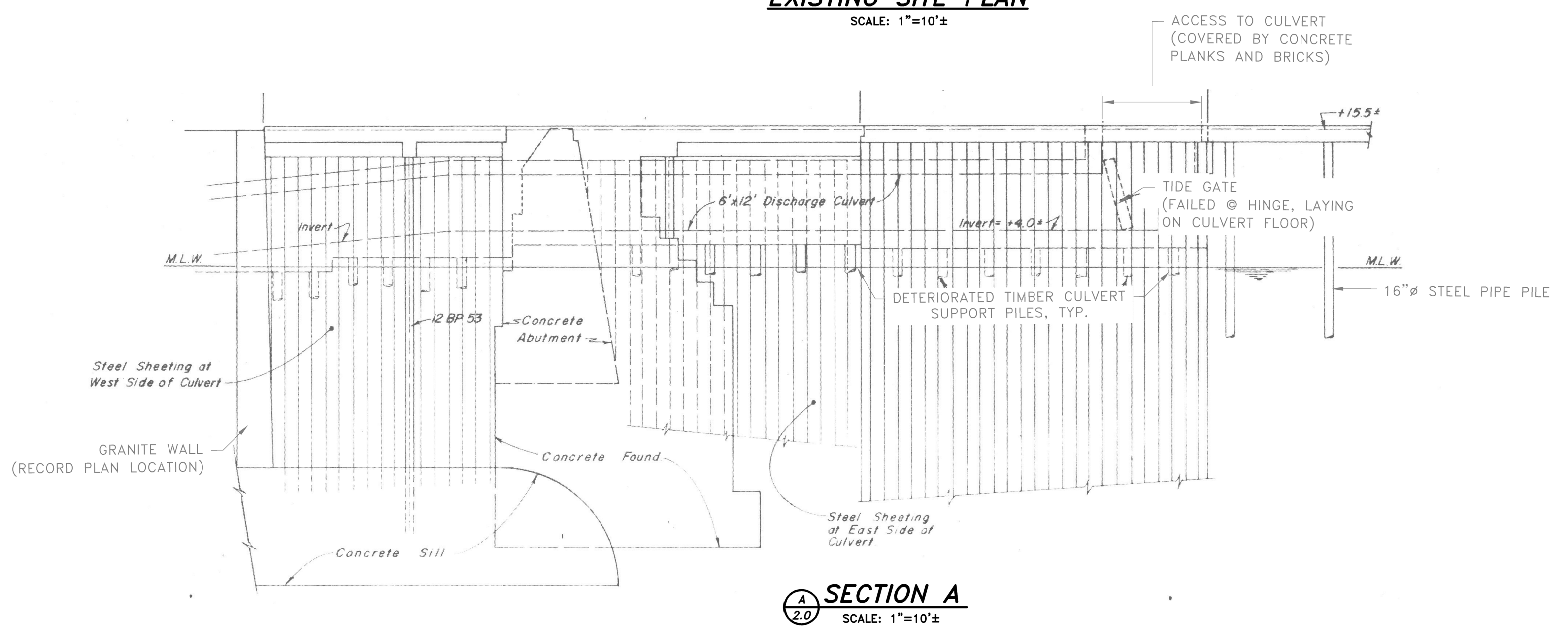
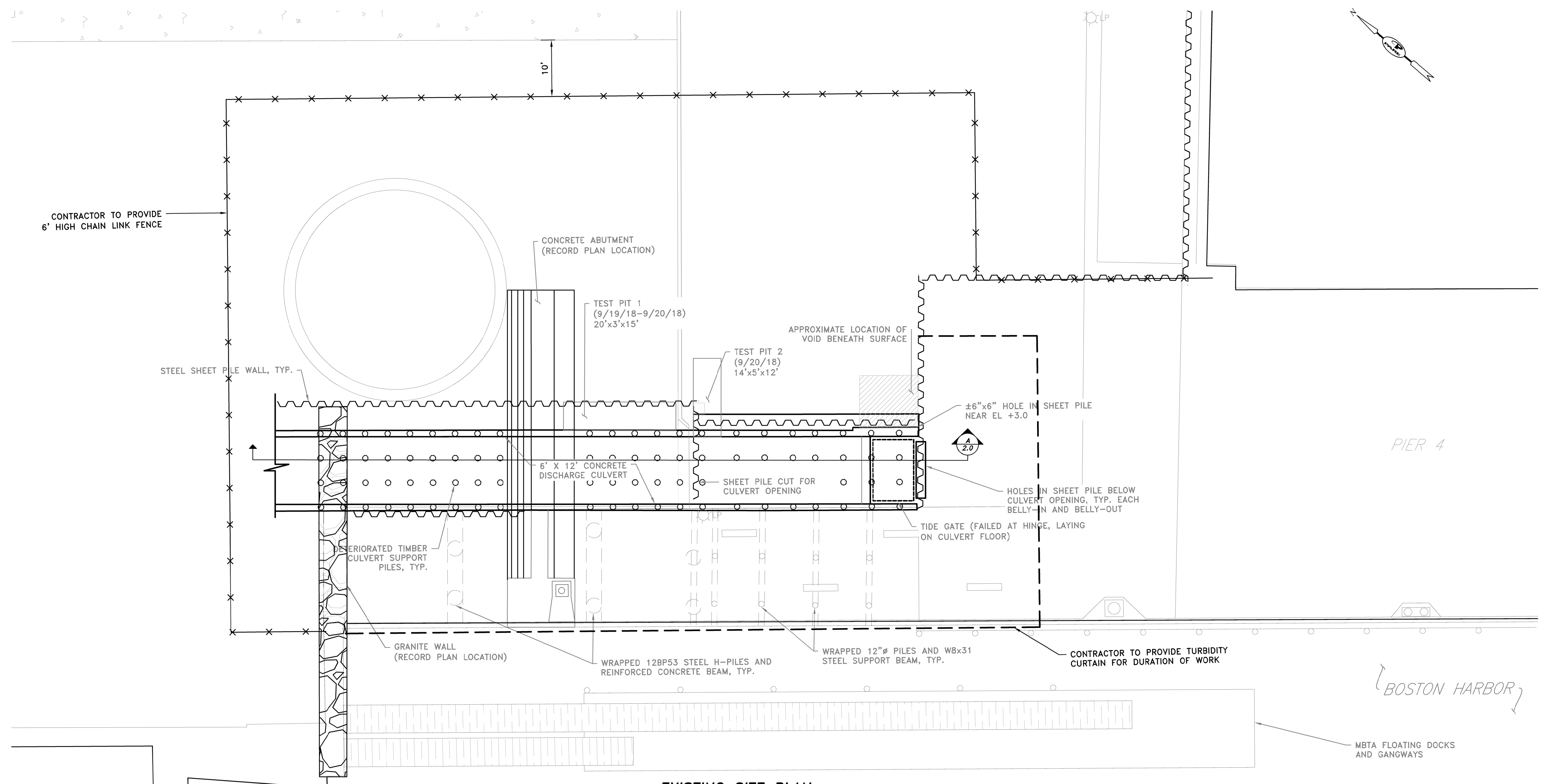

- NOTES**
1. PLAN DEVELOPED FROM AVAILABLE AERIAL IMAGERY FROM MASSGIS, PLAN SET TITLED "EXISTING CONDITIONS PLAN OF LAND IN BOSTON, (CHARLESTOWN) MASSACHUSETTS" DATED MARCH 17, 2015 PREPARED BY BRYANT ASSOCIATES, INC., AND PLAN SET TITLED "GENERAL BULKHEAD RESTORATION PLAN" DATED APRIL 21, 1981 PREPARED BY TIBBETTS ENGINEERING CORP. INFORMATION IS PROVIDED FOR REFERENCE PURPOSES ONLY.
 2. UNDERGROUND STRUCTURES AND PIPES SHOWN HEREIN ARE APPROXIMATE LOCATIONS BASED ON AVAILABLE RECORD PLANS. THIS PLAN DOES NOT GUARANTEE THAT THE UNDERGROUND UTILITIES SHOWN COMPRISE ALL SUCH UTILITIES IN THE AREA. EITHER IN SERVICE OR ABANDONED, THE UNDERGROUND UTILITIES SHOWN MAY NOT BE IN THE EXACT LOCATION INDICATED AND HAVE NOT BEEN PHYSICALLY LOCATED.
 3. ELEVATIONS REFERENCE BOSTON CITY BASE ACCORDING TO DRAWING DATED MARCH 17, 2015.

PERMIT SUBMISSION
 NOT FOR CONSTRUCTION



REVISIONS:	

PROJECT NO.:	18228.00
DATE:	FEBRUARY 2019
SCALE:	AS NOTED
DESIGNED BY:	DJG
CHECKED BY:	RMM
DRAWN BY:	LMC/DJG
APPROVED BY:	RMM

PROPOSED SITE PLAN

SHEET NO.: 3.0

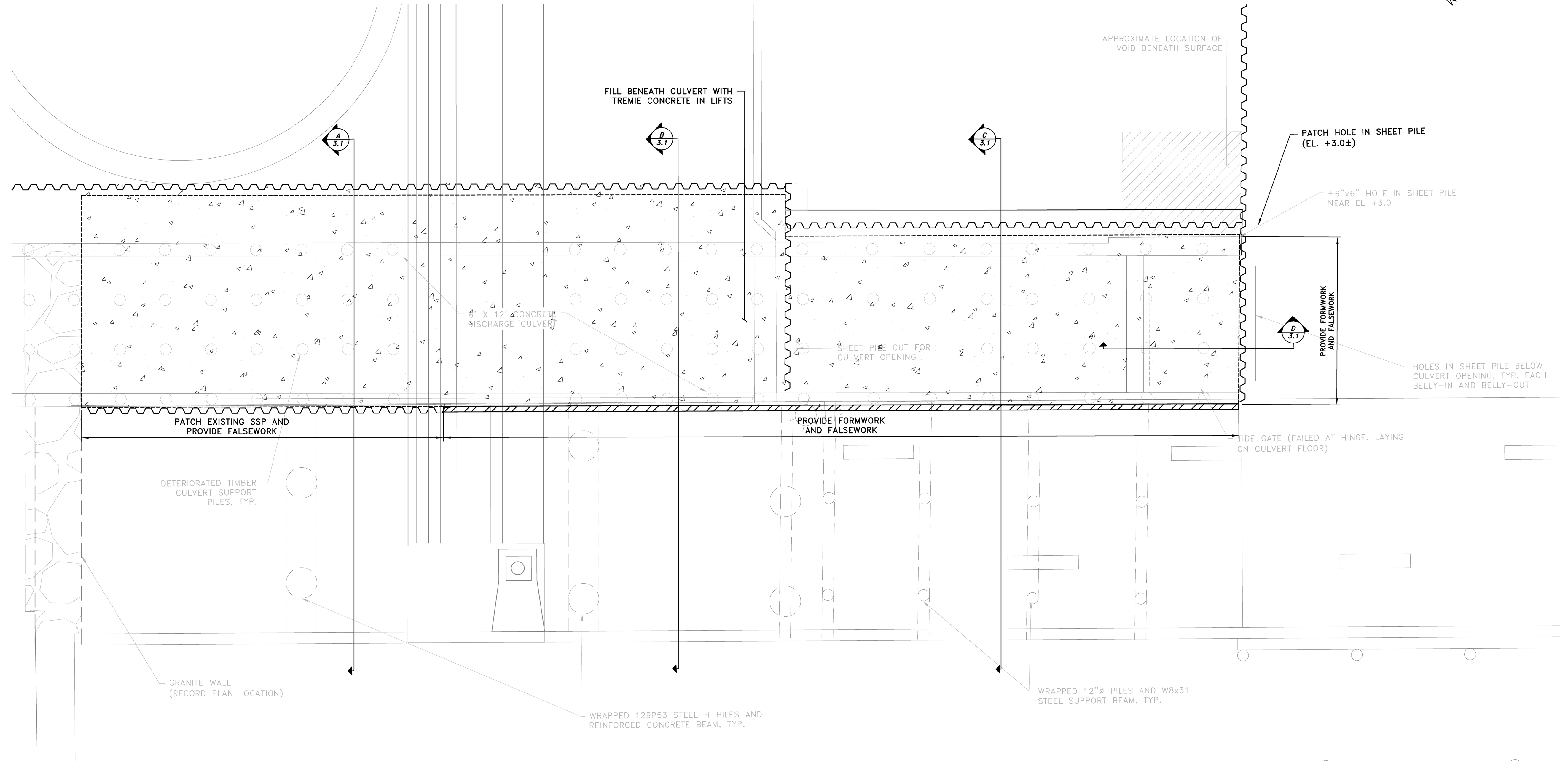

PROPOSED SITE PLAN
 SCALE: 1"=10'±

PROPOSED SCOPE OF WORK

- PRIOR TO PROJECT COMMENCEMENT, NOTIFY AND COORDINATE WITH ALL STATE, LOCAL AND FEDERAL AUTHORITIES AS REQUIRED. NOTIFY DIG-SAFE FOR UTILITY MARKING.
- INSTALL SIGNAGE AND SECURITY FENCING AS NECESSARY.
- MOBILIZE CONSTRUCTION EQUIPMENT AND PERSONNEL TO THE JOB SITE.
- INSTALL EROSION AND SEDIMENT CONTROLS AS NECESSARY.
- INSTALL TEMPORARY SHORING, FALSEWORK AND SUPPORTS AS REQUIRED.
 - CONTRACTOR SHALL ENSURE THAT ADEQUATE SIDE SLOPES, SHORING, AND FALSEWORK ARE PROVIDED AT THE EXCAVATION AND AREA OF WORK RESULTING IN A STABLE AND SAFE STRUCTURE AT ALL TIMES. CONTRACTOR IS ADVISED THAT THE EXISTING CULVERT TIMBER SUPPORT PILES, STEEL SHEET PILES, WALLS, WALE, AND TIE RODS ARE DETERIORATED, THEREFORE THE STRUCTURAL CAPACITY OF THE SYSTEM MAY BE REDUCED.
- PATCH HOLES IN THE EXISTING STEEL SHEET PILE AS INDICATED.

- PLACE CONCRETE FILL BELOW CULVERT.
 - CONCRETE SHALL BE TREMIE MIX PLACED IN 3-FOOT MAXIMUM LIFTS, OR AS PROVIDED BY THE CONCRETE PLACEMENT SUBMITTAL PREPARED AND STAMPED BY A PROFESSIONAL ENGINEER IN THE STATE OF MASSACHUSETTS. CONCRETE SHALL BE PLACED IN THE DRY WHEN POSSIBLE.
 - THE CONTRACTOR SHALL ENSURE THAT FALSEWORK IS DESIGNED TO AVOID EXCESSIVE DEFLECTION OR OVERSTRESSING. ENSURE CONCRETE IS PROPERLY CURED BEFORE REMOVAL OF FORMWORK AND TEMPORARY SHORING.
- REMOVE EXISTING BRICKS AND PAVEMENT, AND EXCAVATE AREAS OF SUBSIDENCE AS INDICATED. BACKFILL WITH IMPORTED GRAVEL FILL COMPACTED IN 12" MAXIMUM LIFTS, PROVIDE NEW FULL DEPTH PAVEMENT, AND RESET BRICKS AS REQUIRED.
- PERFORM SITE CLEANUP AND RESTORATION AS REQUIRED.
- PERFORM FINAL WALKTHROUGH WITH KEY PROJECT PERSONNEL UPON COMPLETION.
- COMPLETE DEMOBILIZATION AND PROJECT CLOSEOUT

NOTES:

- THE CONTRACTOR STAGING AREA AND LIMITS OF CHAIN LINK FENCE SHOWN ARE APPROXIMATE AND SHALL BE COORDINATED WITH THE OWNER PRIOR TO INSTALLATION.
- CONTRACTOR SHALL REMOVE TEMPORARY CHAIN LINK FENCE AND RESTORE THE STAGING AREA TO PRE-CONSTRUCTION CONDITION PRIOR TO DEMOBILIZATION.

PERMIT SUBMISSION
 NOT FOR CONSTRUCTION



PARE CORPORATION
 ENGINEERS - SCIENTISTS - PLANNERS
 10 LINCOLN ROAD, SUITE 210
 FOXBORO, MA 02035
 508-943-1735

SCALE ADJUSTMENT GUIDE
 0" 1"
 BAR IS ONE INCH ON ORIGINAL DRAWING.

PIER 4 CULVERT AND SINKHOLE REPAIRS
 CHARLESTOWN NAVY YARD
 BOSTON, MASSACHUSETTS
 BOSTON PLANNING AND DEVELOPMENT AGENCY



REVISIONS:

PROJECT NO.: 18228.00
 DATE: FEBRUARY 2019
 SCALE: AS NOTED
 DESIGNED BY: DJG
 CHECKED BY: RMM
 DRAWN BY: LMC/DJG
 APPROVED BY: RMM

PROPOSED SECTIONS AND DETAILS

SHEET NO.: **3.1**

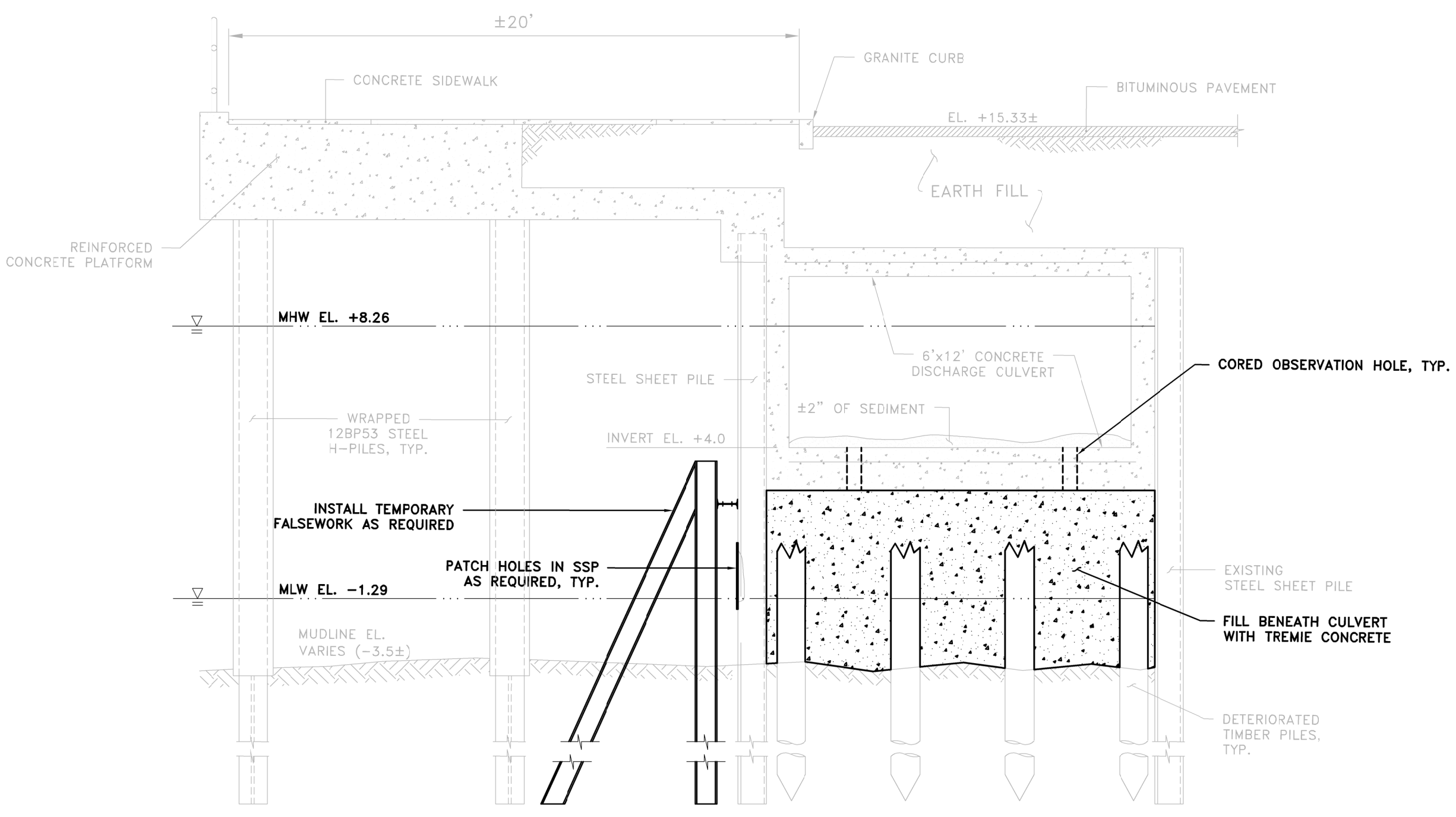

A PROPOSED REPAIR SECTION
 NOT TO SCALE

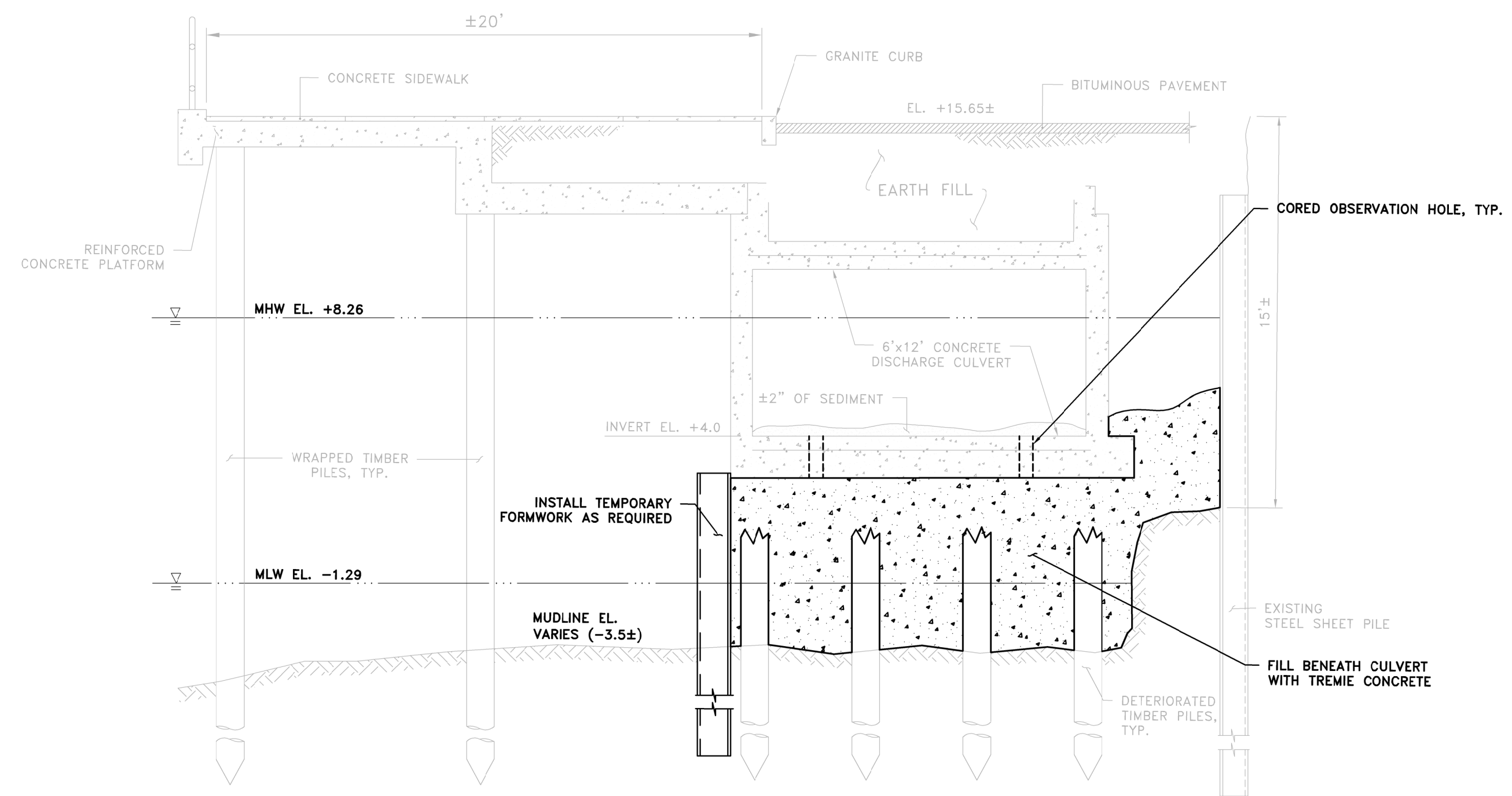

B PROPOSED REPAIR SECTION
 NOT TO SCALE

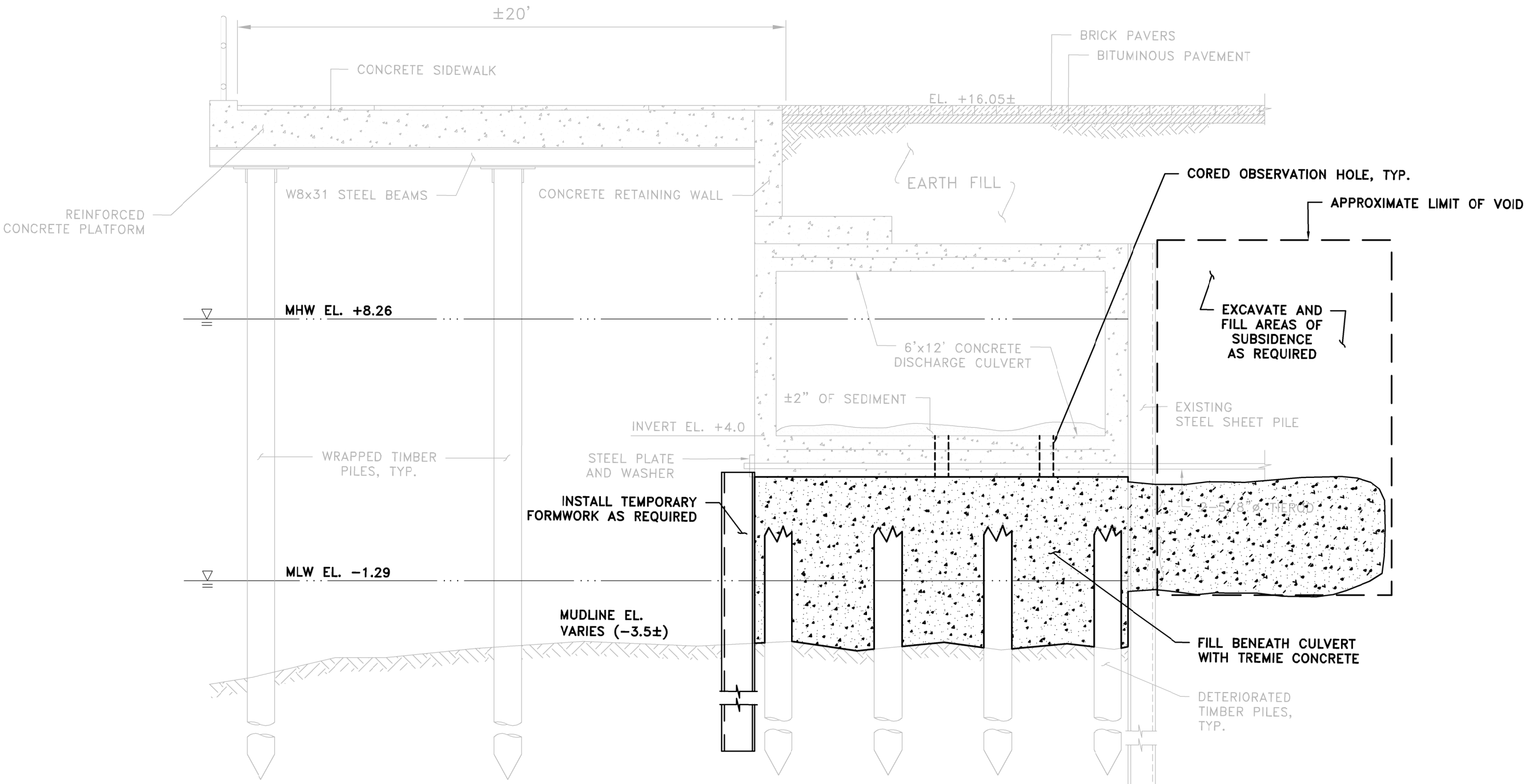

C PROPOSED REPAIR SECTION
 NOT TO SCALE

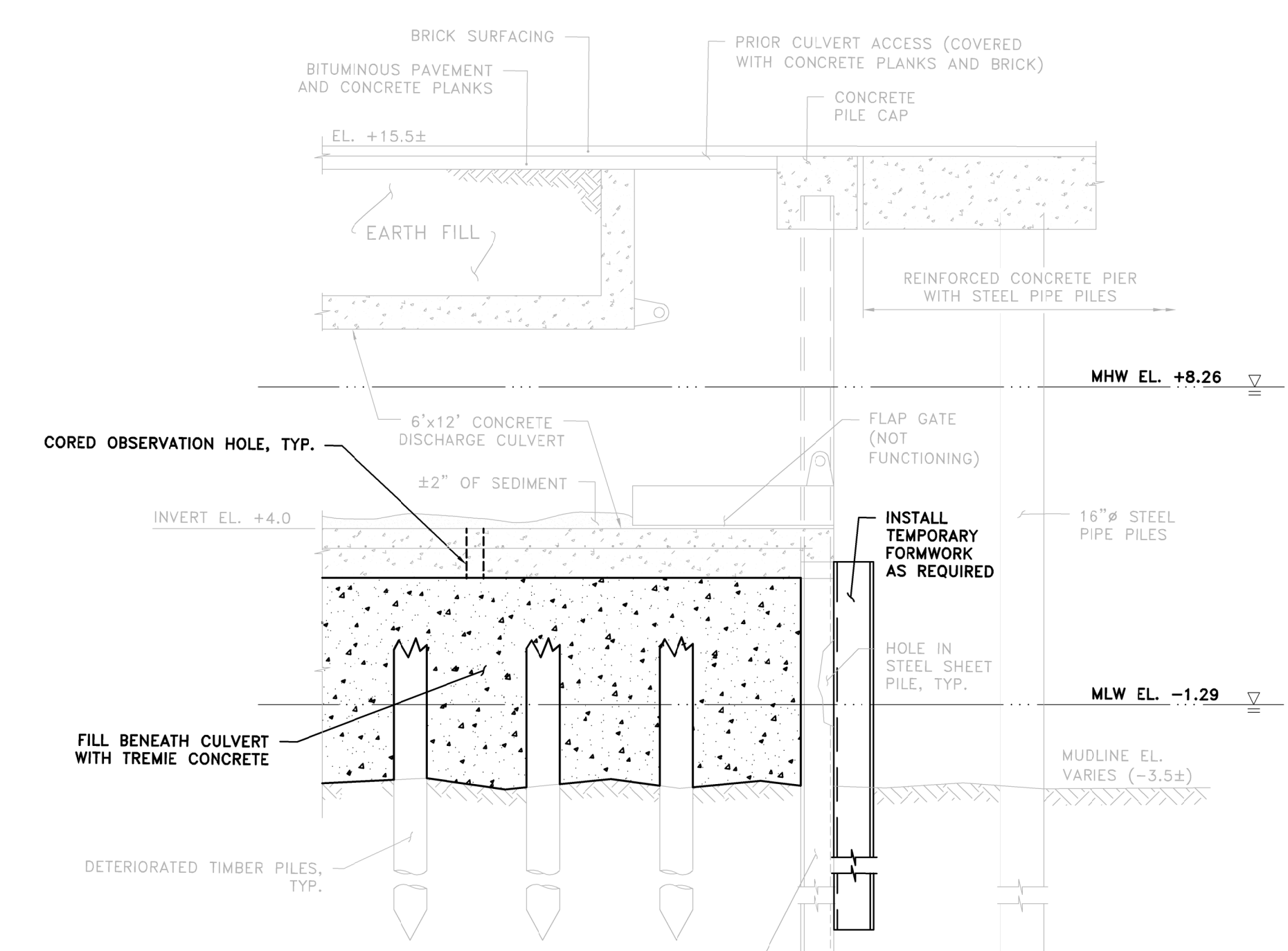

D PROPOSED REPAIR SECTION
 NOT TO SCALE

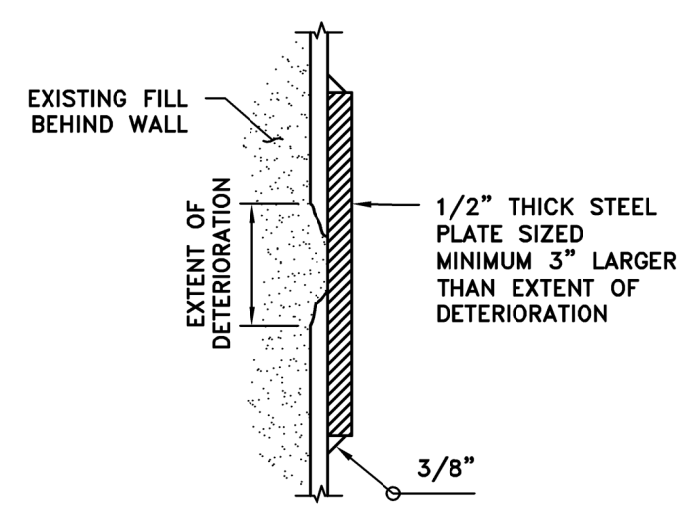

SHEET PILE HOLE REPAIR SECTION
 NOT TO SCALE

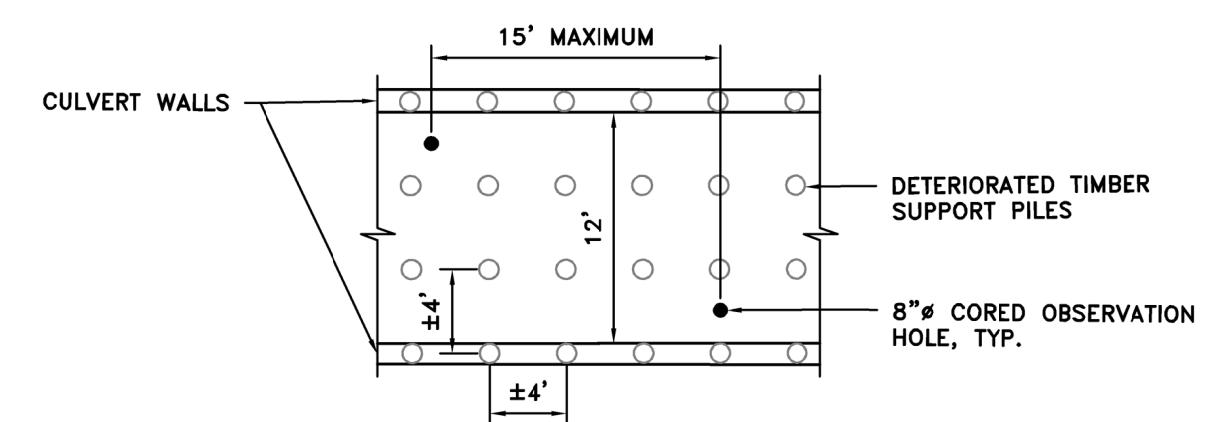

OBSERVATION HOLE PART PLAN
 SCALE: 1"=10'±

PERMIT SUBMISSION
 NOT FOR CONSTRUCTION

Y:\066118 Joss\18228.00 BPA - Charlestown Pier 4 Sinkhole - MA\DWG\3.1 PROPOSED SECTIONS AND DETAILS.dwg



PARE CORPORATION
 ENGINEERS - SCIENTISTS - PLANNERS
 10 LINCOLN ROAD, SUITE 210
 FOXBORO, MA 02035
 508-943-1755

SCALE ADJUSTMENT GUIDE
 0" 1"
 BAR IS ONE INCH ON ORIGINAL DRAWING.

PIER 4 CULVERT AND SINKHOLE REPAIRS

CHARLESTOWN NAVY YARD
BOSTON, MASSACHUSETTS
 BOSTON PLANNING AND DEVELOPMENT AGENCY



REVISIONS:	

PROJECT NO.: 18228.00
 DATE: FEBRUARY 2019
 SCALE: AS NOTED
 DESIGNED BY: DJG
 CHECKED BY: RMM
 DRAWN BY: LMC/DJG
 APPROVED BY: RMM

PROPOSED SITE RESTORATION PLAN

SHEET NO.: 4.0

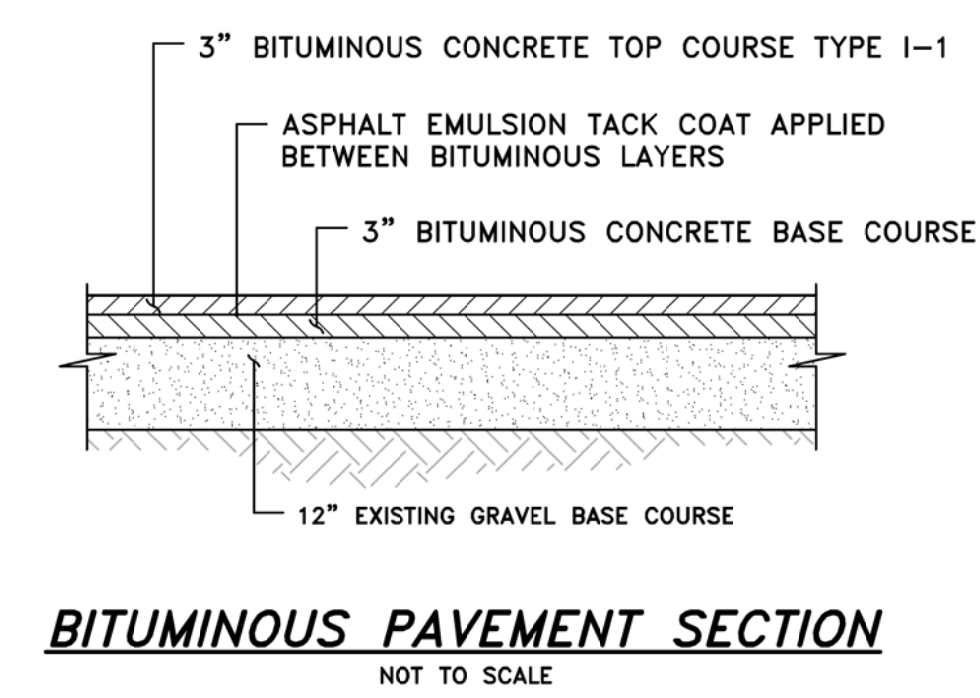
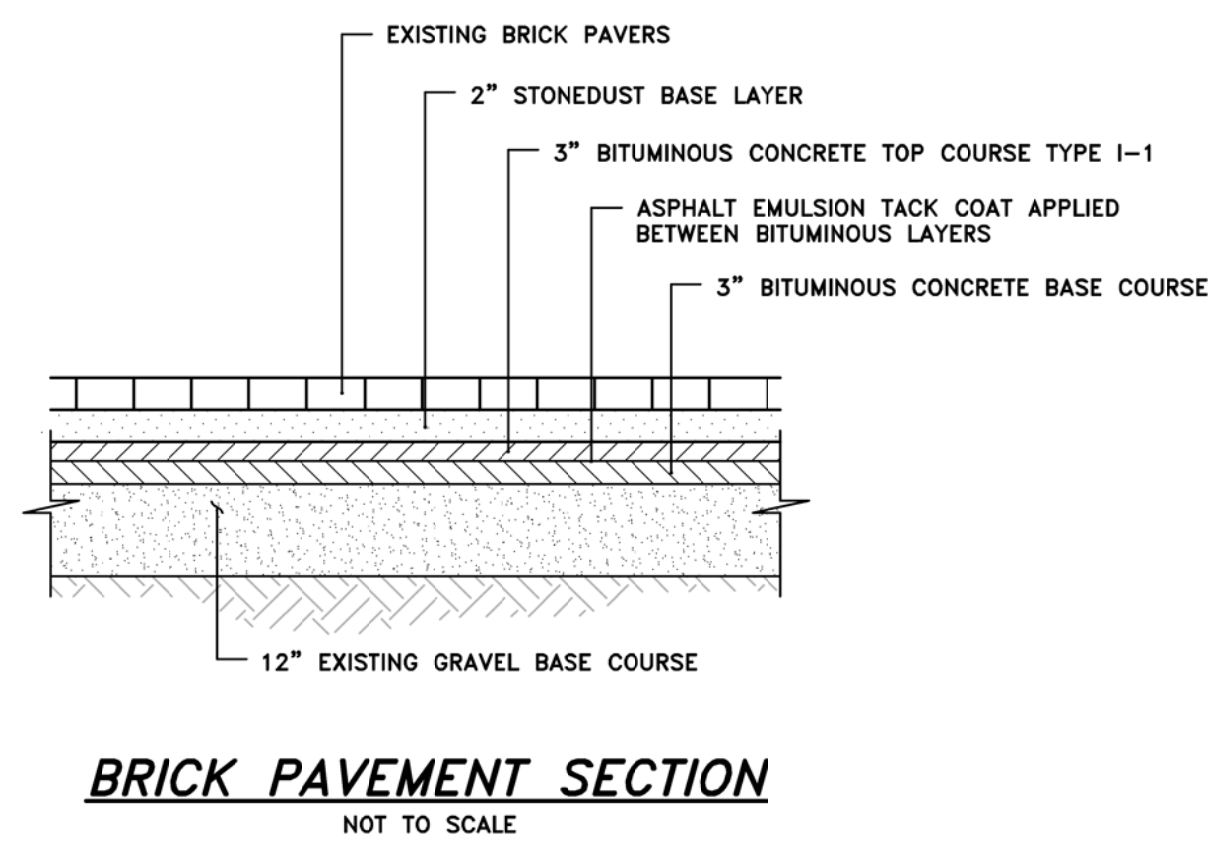
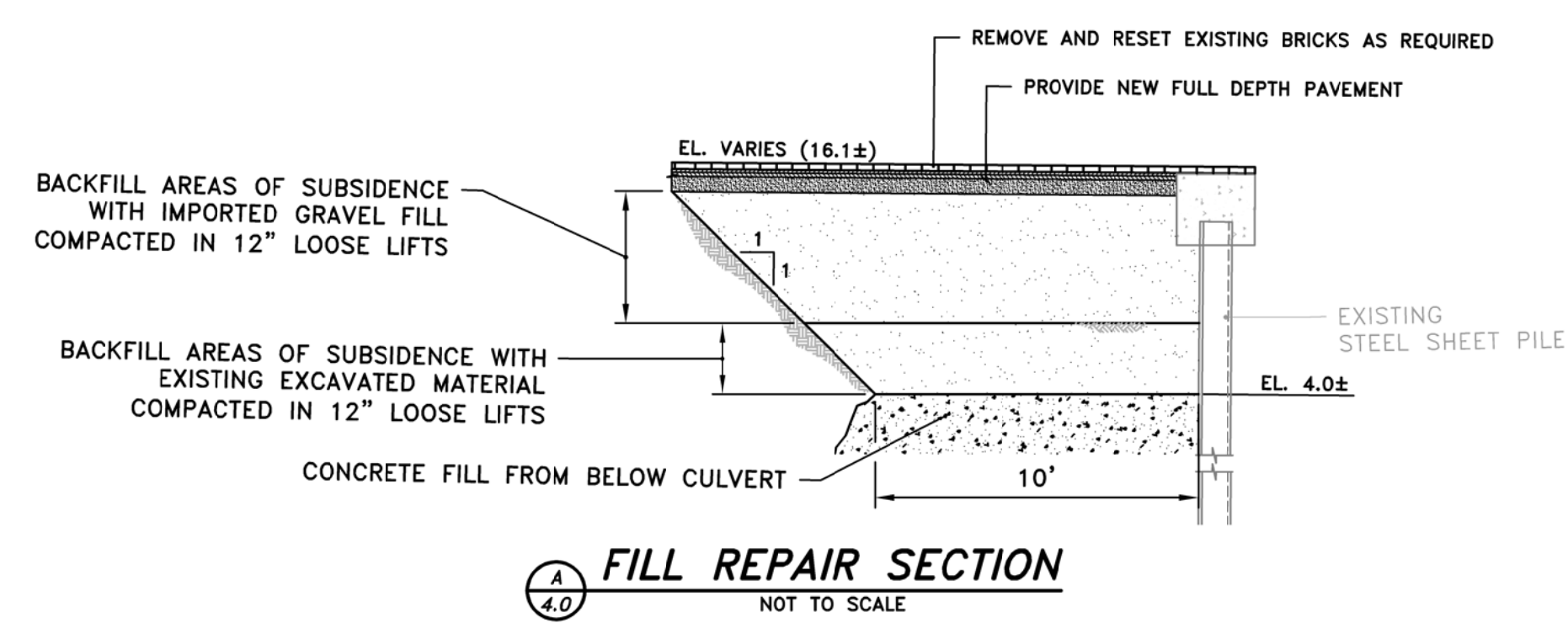
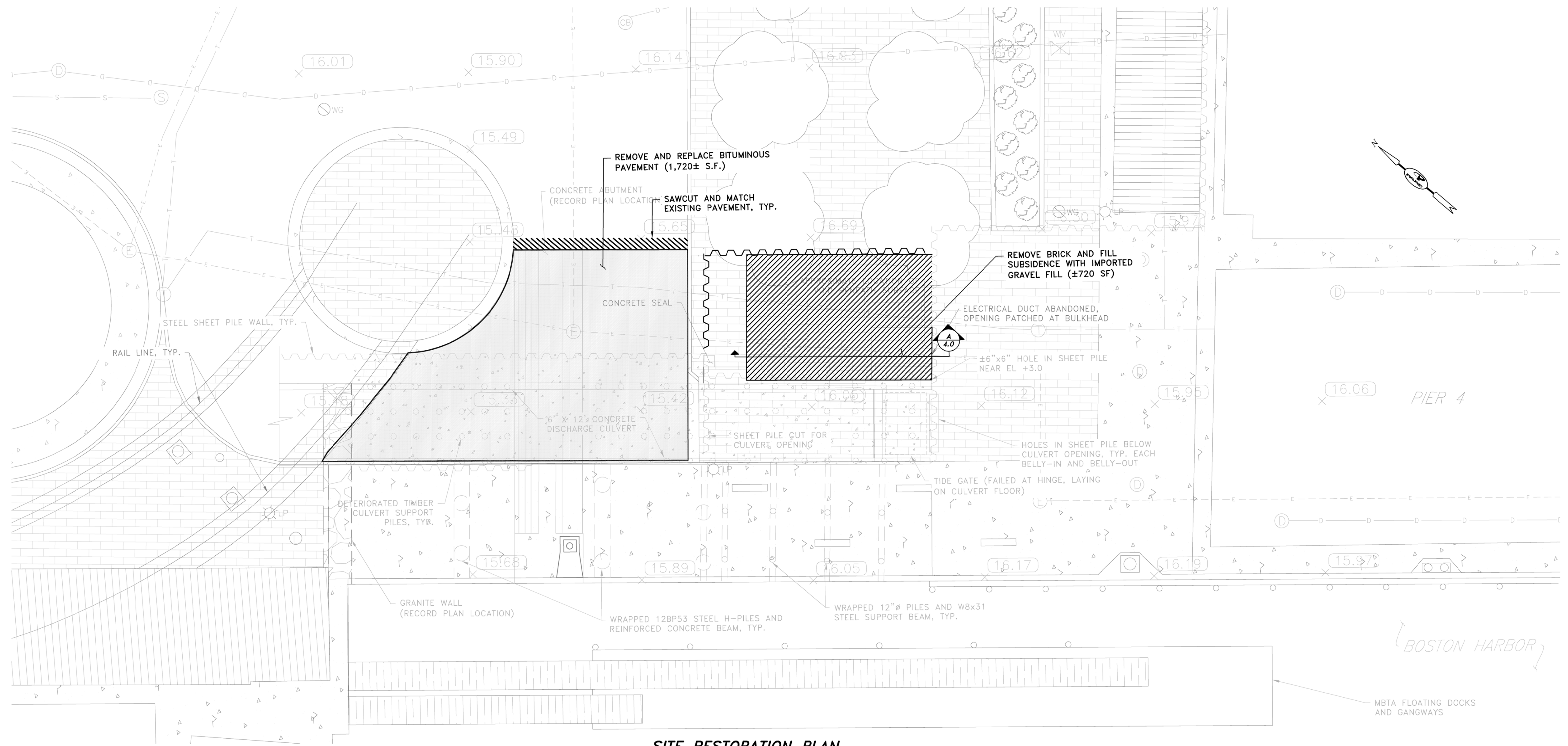

PERMIT SUBMISSION
 NOT FOR CONSTRUCTION

Y:\085\18_00s\18228.00 BPA - Charlestown Pier 4 Sinoe - MA\DWG\4.0 SITE RESTORATION PLAN.dwg