



APPLICATION
CERTIFICATE of APPROPRIATENESS-or-
DESIGN APPROVAL-or-EXEMPTION

Deliver or mail to:
Environment Department
Boston City Hall, Rm 709
Boston, MA 02201

For Office Use Only

APPLICATION # _____

RECEIVED _____

FEE _____

HEARING DATE _____

DO NOT RETURN THIS FORM BY FAX OR EMAIL

DO NOT STAMP THIS BOX

I. PROPERTY ADDRESS 396 Beacon Street, #6 Boston, MA 02116

NAME of BUSINESS/PROPERTY _____

The names, telephone numbers, postal and e-mail addresses requested below will be used for all subsequent communications relating to this application. Environment Department personnel cannot be responsible for illegible, incomplete or inaccurate contact information provided by applicants.

II. APPLICANT Otto Iglesias

CONTACT NAME Same RELATIONSHIP TO PROPERTY owner
MAILING ADDRESS 25 Langford Road ZIP 02360
PHONE 857-268-1025 EMAIL otto.h.iglesias@gmail.com

PROPERTY OWNER Same CONTACT NAME Same
MAILING ADDRESS ↓ ZIP _____
PHONE ↓ EMAIL ↓

ARCHITECT _____ CONTACT NAME _____
MAILING ADDRESS _____ ZIP _____
PHONE _____ EMAIL _____

CONTRACTOR JB Sash & Door Company CONTACT NAME Cheryl Carney
MAILING ADDRESS 280 Second Street, Chelsea, MA ZIP 02150
PHONE 617-884-8940 x235 EMAIL cherylc@jbsash.com

III. DESCRIPTION OF PROPOSED WORK

A BRIEF OUTLINE OF THE PROPOSED WORK **MUST BE GIVEN IN THE SPACE PROVIDED BELOW, OR THE APPLICATION WILL NOT BE ACCEPTED.** This description provides the basis for the official notice and subsequent decision, and it must clearly represent the entirety of the project. Additional pages may be attached, if necessary, to provide more detailed information.

Ground Floor

Replace 3 front facing 2/2 windows with all wood custom JB Proper Bostonian true divided lite 2/2 windows in kind. Exterior to be painted black to match existing. No change to brick mold.

REQUIRED DOCUMENTATION: Please include all required documentation with this application; review instructions carefully for details.

ESTIMATED COST OF PROPOSED WORK: \$7,910.83

IV. DULY AUTHORIZED SIGNATURES (both required)

The facts set forth above in this application and accompanying documents are a true statement made under penalty of perjury.

* APPLICANT

[Handwritten Signature]

* OWNER*

[Handwritten Signature]

*(If building is a condominium or cooperative, the chairman must sign.)

* PRINT

OTO Ighesias

* PRINT

OTO Ighesias

Trustee

Environment Department personnel cannot be responsible for verifying the authority of the above individuals to sign this application. Misrepresentation of signatory authority may result in the invalidation of the application. UNSIGNED OR PARTIALLY SIGNED FORMS WILL BE REJECTED

THIS APPLICATION IS NOT COMPLETE WITHOUT SIGNATURES, FEES AND REQUIRED DOCUMENTATION. The checklist below is for reference only: Please refer to the detailed application instructions for deadlines, fee schedule and required documentation specific to your proposal.



COMPLETED APPLICATION FORM



APPLICATION FEE (Check or money order made payable to City of Boston; see fee schedule in Instructions)



DESCRIPTION OF WORK (A brief description must be included on the front page; additional pages of detailed information may be attached. Applications that only note "see attached" will not be accepted.)



PHOTOS OF EXISTING CONDITIONS



DRAWINGS AND SPECIFICATIONS AS REQUIRED (See "documentation requirements" in instructions)

Otto Iglesias
396 Beacon Street #6
Boston, MA 02116



Otto Iglesias
396 Beacon Street #6
Boston, MA 02116



0112 Iglesias
394 Beacon Street #6
Boston, MA 02112



Otto Iglesias
396 Beacon street #6
Boston, MA 02116



Otto Iglesias
396 Beacon Street #6
Boston, MA 02116



Otto Iglesias
396 Beacon Street #6
Boston, MA 02116



6th Iglesia
396 Beacon Street #6
Boston, MA 02112

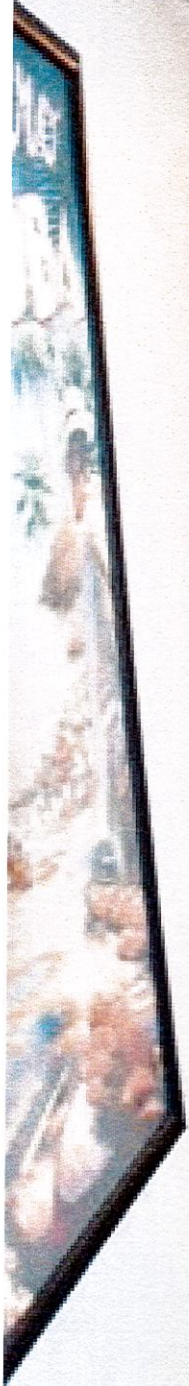

JB PROPER BOSTONIAN SH WINDOW UNIT

0775 Iglesias
 396 Beacon Street #4
 Boston, MA 02116

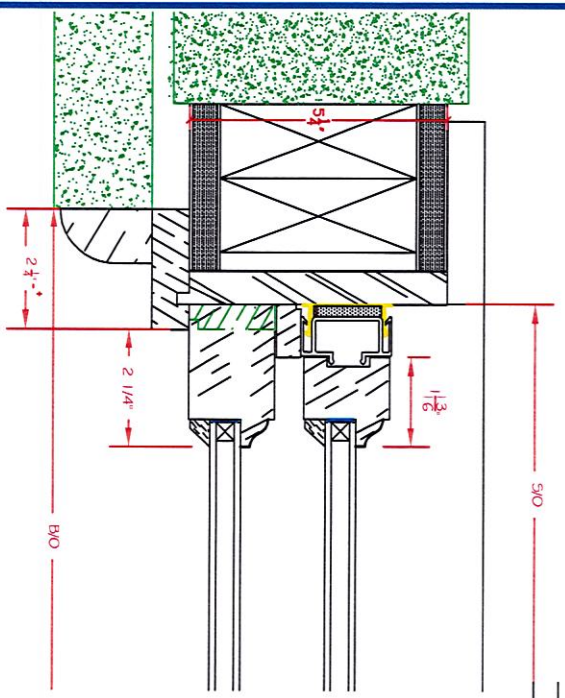
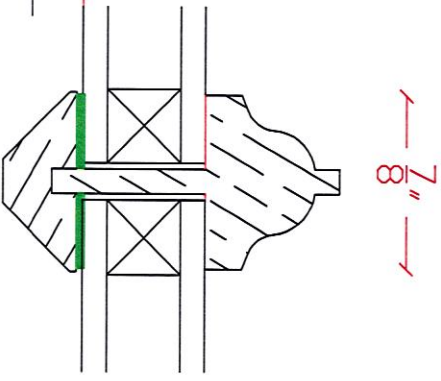
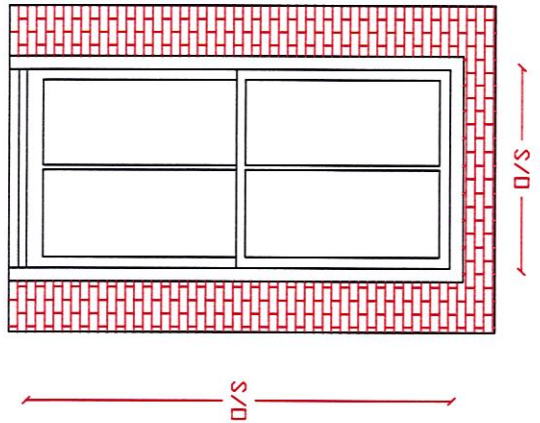

JAMB SECTION

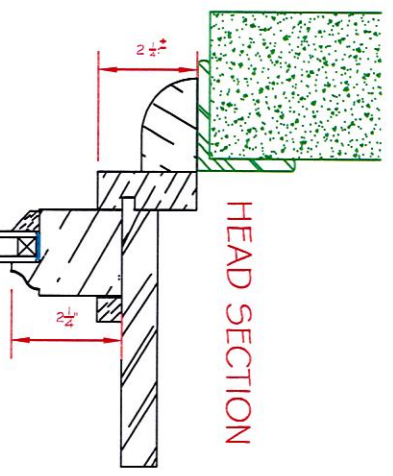

HEAD SECTION

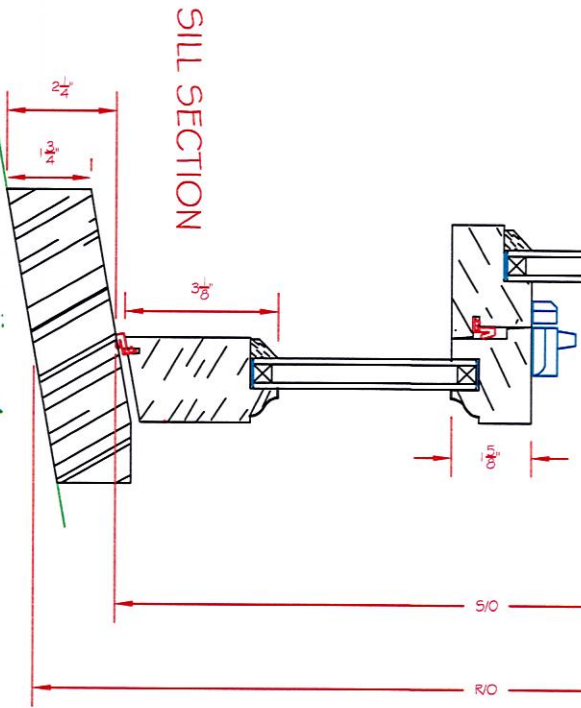

SILL SECTION

T.D.L. BAR
 FULL SCALE

DEALER: JB SASH & DOOR CO., INC.
 NUMBER: DATE: 02/26/16
 DRAWN: R.L.B. CHECK:

JBPB SH REPL/UNIT - 2/2

SHEET 1
 OF 1

Change Order # 4

Otto Iglesias
396 Beacon Street #6
Bostm. MA 02116

Date: Oct. 31, 2013

Original Contract Date: July 15, 2013

Original Contract Total: \$ 24,375.00

Description:

Restoration of window (to include)

Remove three (3) Windows

Replace Glass

Sand down and remove old paint interior and exterior

Re-paint Exterior

Cost:

\$ 1,500.00

Updated Contract Price (change order # 1 , # 2 & #3)

\$ 28,225.00

New Contract Price:

\$ 28,725.00

Thank You

Joseph James Morra

Otto Iglesias
396 Beacon Street #6
Boston, MA 02116

CONTRACTORS INVOICE

No: 2013-182

Joseph James Morra
90 Hillcrest Ave
West Hartford, Ct 06110
860-817-2161

TO:

Otto Iglesias
396 Beacon St./Unit 6
Boston, MA. 02116

WORK PERFORMED AT:

396 Beacon Street
Unit 6
Boston, MA 02116

DATE:

Dec. 20, 2013

YOUR PURCHASE ORDER NO.

2013-182

DESCRIPTION OF WORK PERFORMED:

| | |
|--|-------------|
| Change Order No. 8 Remove and Restore Exterior Windows | \$ 1,500.00 |
| Partial Change Order No. 11 Build Vanity <i>200 No 11</i> | \$ 500.00 |
| Total | \$ 2,000.00 |

PAID

Two Thousand and 00/100 dollars _____ (\$2,000.00)

3/21/2018

Otto Iglesias
396 Beacon Street #6 - 396 Beacon Street
Boston, MA 02116



Otto H. Iglesias <otto.h.iglesias@gmail.com>

396 Beacon Street

1 message

Young, William <William.Young@cityofboston.gov>
To: "otto.h.iglesias@gmail.com" <otto.h.iglesias@gmail.com>
Cc: "j.morra15@yahoo.com" <j.morra15@yahoo.com>

Mon, Aug 26, 2013 at 6:41 PM

Dear Mr. Iglesias:

Your application to replace 3 units of window sash at the above property has been received; thank you. Please note that Back Bay Architectural District guidelines (available for your review at www.cityofboston.gov/landmarks/historic/backbay.asp) require the use of wood replacement windows. These cannot be clad in any other material and must replicate the original design (if there is more than one pane per sash, true-divided-light construction is required). Thus the clad, one-over-one Andersen windows you propose are not acceptable replacements for two-over-two wood originals. I would accordingly encourage you to revise your application to propose wood, true-divided-light, two-over-two units. It is possible that Home Depot does not sell windows that meet the guidelines. In that event, you will need to find another source. Alternatively, you may repair your existing windows. A link to the benefits of retaining and repairing historic windows may be found at the commission's web site (link above).

Thanking you for your attention to the guidelines,

Very truly,

BACK BAY ARCHITECTURAL COMMISSION

William S. Young

Assistant Director for Historic Districts

City of Boston

Environment Department

Boston City Hall, rm. 805

Boston, MA 02201

Telephone [617.635.3850](tel:617.635.3850)

Facsimile [617.635.3435](tel:617.635.3435)

william.young@cityofboston.gov